

# Katalog

Ausgabe: 2020

## Stanzwerkzeuge

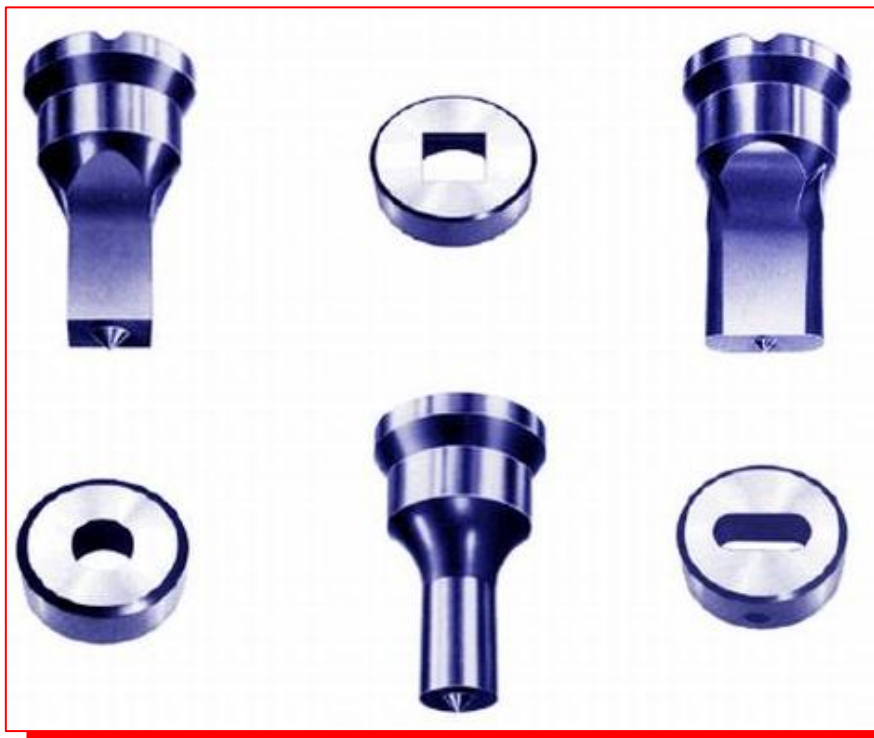

**GEKA**

## Ansprechpartner

---

**Johann Fischer**  
Firmeninhaber

Tel: +49 (0) 7854 877 38 51  
E-Mail: [fischer@bk-services.de](mailto:fischer@bk-services.de)

---

**Nico Fischer**  
Geschäftsführer  
Bereich: Profilstahlscheren – Lochstanzen, Sonderwerkzeuge & Qualitätsmanagement

Tel: +49 (0) 7854 877 38 21  
E-Mail: [nico.fischer@kewema.de](mailto:nico.fischer@kewema.de)

---

**Florian Fischer**  
Vertrieb / Technik  
Bereich: Profilstahlscheren - Lochstanzen, Standardwerkzeuge & Maschinenersatzteile

Tel: +49 (0) 7854 877 38 23  
E-Mail: [florian.fischer@kewema.de](mailto:florian.fischer@kewema.de)

---

**Inge Fischer**  
Personalwesen  
Rechnungswesen

Tel: +49 (0) 7854 877 38 22  
E-Mail: [inge.fischer@kewema.de](mailto:inge.fischer@kewema.de)

---

**Aline Spothelfer**  
Vertrieb / Technik  
Bereich: Standard- & Sonderwerkzeuge, Rechnungswesen

Tel: +49 (0) 7854 877 38 24  
E-Mail: [aline.spothelfer@kewema.de](mailto:aline.spothelfer@kewema.de)

---

**Michael Krämer**  
Vertrieb / Technik  
Bereich: Profilstahlscheren – Lochstanzen, Sonderwerkzeuge & Qualitätsmanagement

Tel: +49 (0) 7854 877 38 26  
E-Mail: [michael.kraemer@kewema.de](mailto:michael.kraemer@kewema.de)

---

**Diane Dietrich**  
Materialwirtschaft / Einkauf / Lager  
Bereich: Materialbeschaffung

Tel: +49 (0) 7854 877 38 25  
E-Mail: [diane.dietrich@kewema.de](mailto:diane.dietrich@kewema.de)

---

## Inhalt

## Contents

### Kapitel 1

Stempel & Matrizen für motorisch betriebene Stanzen und Mehrstempelwerkzeuge

**1**

Punches & dies for motor-driven punching machines and multiple punching tools

### Kapitel 2

Maschinenersatzteile

**2**

Machine spare parts

Dieser Katalog zeigt – in klarer Gliederung – das komplette Geka-Programm über genormte Stempel und Matrizen für die rationelle Blech-, Flach- und Profilstahlbearbeitung. Alle hier aufgeführten Werkzeuge sind kurzfristig lieferbar.

Alle Werkzeuge dieses Kataloges sind für die Bearbeitung von Material bis zu einer Festigkeit von 600 N/mm<sup>2</sup> geeignet. Werkzeuge zur Bearbeitung von Material mit höherer Festigkeit werden auf Wunsch gesondert gefertigt.

Bei den in diesem Katalog aufgeführten Langlochwerkzeugen entspricht der Radius der halben Lochbreite. Falls erforderlich, abweichende Radien bitte angeben. Diese Werkzeuge werden in Sonderanfertigung hergestellt.

Für jedes Werkzeug bitte die komplette Artikel-Nummer angeben.

Bestell-Beispiel:

Stempel 50599 9  
 Schnittform: Rund  
 10 Stück Abmessung: 3,0 mm  
 Artikel-Nummer: 5059991030

Die Größe des zu stanzenden Loches wird durch die Abmessung des Stempels bestimmt. Die Stempel sind mit diesem Maß gekennzeichnet.

Die Öffnung der Matrize muss um das Schneidspiel ( = 2x Schneidspalt ) größer sein. Erfahrungsgemäß sollte das Schneidspiel ca. 10% der Materialstärke betragen. Die Kennzeichnung der Matrize gibt die tatsächliche Abmessung der Schneidöffnung (Öffnung in der Matrize) an.

Bei der Festlegung des Schneidspiels empfehlen wir folgende Regeln:

Für runde und quadratische Schnittform:

Materialstärke:	mm	bis 4	> 4 bis 9	> 9 bis 14	> 14 bis 19	> 19 bis 24
Schneidspiel:	mm	0,2	0,7	1,2	1,7	2,2

Beispiel: Stempeldurchmesser: 20,0 mm  
 Materialstärke: 12,0 mm  
 Matrizenöffnung: 21,2 mm

=> Falls in der Bestellung keine Matrizenabmessungen oder Materialstärken mitgeteilt werden, so wird generell das Schneidspiel 0,7 mm geliefert.

Für Langlochschnittform:

Langlochwerkzeuge werden nach der Geka-Norm mit 0,2 mm und 0,7 mm Schneidspiel gefertigt.

Materialstärke:	mm	bis 6	> 6 bis 9
Schneidspiel:	mm	0,2	0,7

Beispiel: Langlochabmessung: 11,0 x 30,0 mm  
 Materialstärke: 1 – 6 mm  
 = Matrizenöffnung: 11,2 x 30,2 mm  
 Materialstärke: 6 – 14 mm  
 = Matrizenöffnung: 11,7 x 30,7 mm

=> Falls in der Bestellung keine Matrizenabmessungen oder Materialstärken mitgeteilt werden, so wird generell das Schneidspiel 1,0 mm geliefert.

Auf Wunsch werden die hier aufgeführten Stempel und Matrizen Typen als Sonderanfertigung in jeder gewünschten Schnittform hergestellt; z. B. Dreieck-, Rechteck-, Sechskant- sowie in anderen Schnittformen.

Selbstverständlich fertigt KEWEMA GmbH alle Spezialstanzwerkzeuge nach Ihren Angaben (Zeichnung oder Muster).

Bitte beachten Sie beim Einsatz von unseren Stanzwerkzeugen auf folgende grundlegende Punkte:

- Achten Sie bitte auf einen gleichmäßigen Schneidspalt zwischen Stempel- und Matrizenöffnung.
- Die Matrize muss in der Halterung einen festen Sitz haben. Ebenfalls müssen Stempelhalter und Stempelfutter in ihren Halterungen sicher befestigt sein.
- Die Abstreifer / Niederhalter (siehe nachstehende Skizze) müssen gleichmäßig abstreifen und plan zur Matrizenoberfläche stehen.
- Um eine möglichst lange Lebensdauer der Werkzeuge zu erreichen, sollten die Stempel beim Stanzen öfter mit Öl bestrichen werden.
- Beim Einsetzen von Langloch, Vierkant sowie in anderen Spezial-Schnittformen muss der mitgelieferte Verdrehsicherungsstift eingesetzt werden.
- Um eine Überlastung Ihrer Maschine zu vermeiden, empfehlen wir, den beim Stanzen der Löcher entstehenden Stanzdruck nach folgender Formel zu überprüfen. Die max. Stanzkraft ist aus dem Leistungsschild an Ihrer Maschine ersichtlich.

$$\text{Stanzkraft (F)} = \frac{\text{Umfang Stempel } (\pi \times d) \times \text{Materialstärke (s)} \times \text{Zugfestigkeit (Rm)} \times [\text{Faktor } 0,8]}{9810 \text{ (Umrechnung Nm in t)}}$$

Rm = Zugfestigkeit (N/mm<sup>2</sup>):

Edelstahl	1.4301	=	720 N/mm <sup>2</sup>
Stahl	St 37	=	420 N/mm <sup>2</sup>
Aluminium	AlMg3	=	220 N/mm <sup>2</sup>

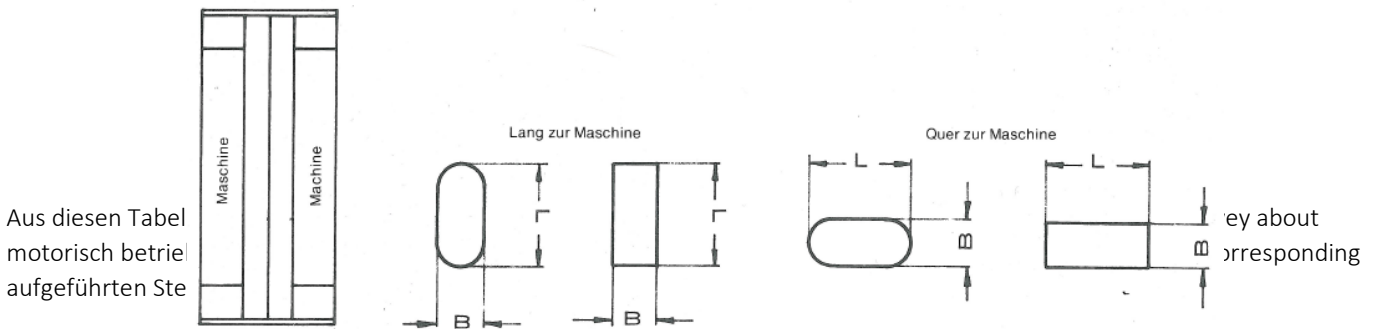

Maschinenmodell	Stempel		Matrize		Stanzkraft		Stanzhöhe
	Ø	h	Ø	h	max	min	mm
Multi - II							17
PP 50							22
Mircrocrop 36	5,15	27	27	53	30,5	5	50,8
Minicrop 45	5 / 27		27		30,5	5	25,5
Multicrop 45							17
Hydracrop 50 - 70							
Puma 50 - 70	6		28	58	31,5	6	46
							28,5

Bendicrop 50	8 / 31		31	64	35	5	50,8	25,5			
Hydracrop 55 – 80 Puma 55 – 80	8 / 19		19	64	24	5	50,8	25,5			
	8 / 31		31		35						
	8 / 40		40		43,5						
Hydracrop 100 Puma 100	8 / 19		19		24	8	60	32			
	8 / 31		31		35						
Hydracrop 110 Puma 110	8 / 19		19		64	24	10	73	32		
	8 / 31		31	35							
	8 / 40		40	43,5							
Hydracrop 150 – 200 Puma 150 – 200	10 / 26		26	73	29,5						
	10 / 40		40		43,5						
Minicrop 45 Multicrop 45 Hydracrop 50 – 70 – 100 Puma 50 – 70 – 100 Hydracrop 55 – 80 – 110 Puma 55 – 80 – 110	11		50	58	54	11				78	28,5
	12		75		79	12	100				
	13		100		104	13	125				
Hydracrop 150 – 200 Puma 150 - 200	11A		50	73	54	11	78				
	12A		75		79	12	100				
	13A		100		104	13	125				

**Kapitel 1**

Stempel & Matrizen für motorisch betriebene Stanzen und Mehrstempelwerkzeuge  
 Punches & dies for motor-driven punching machines and multiple punching tools

**1**

**Rundstempel Nr. 5**

**Round Punch No. 5**

**Code 50599 9 1**

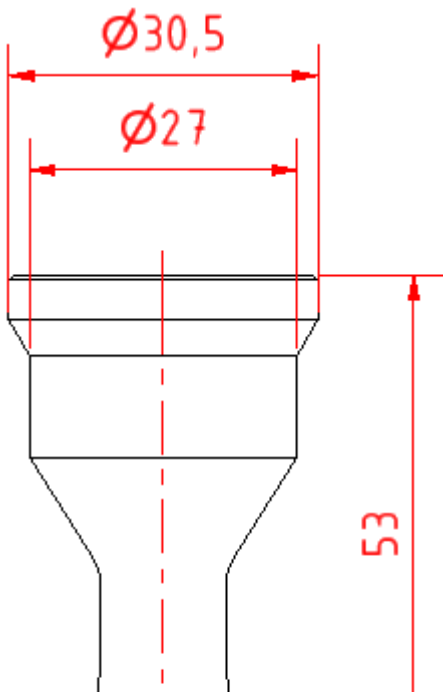

Menge	Artikelnummer	Abmessung
	5059991030	3.0 mm
	5059991035	3.5 mm
	5059991040	4.0 mm
	5059991045	4.5 mm
	5059991050	5.0 mm
	5059991055	5.5 mm
	5059991060	6.0 mm
	5059991065	6.5 mm
	5059991070	7.0 mm
	5059991075	7.5 mm
	5059991080	8.0 mm
	5059991085	8.5 mm
	5059991090	9.0 mm
	5059991095	9.5 mm
	5059991100	10.0 mm

	5059991105			10.5 mm
	5059991110			11.0 mm
	5059991115			11.5 mm
	5059991120			12.0 mm
	5059991125		$\varnothing 20.5$	12.5 mm
	5059991130			13.0 mm
	5059991135			13.5 mm
	5059991140			14.0 mm
	5059991145		$\varnothing 21$	14.5 mm
	5059991150			15.0 mm
	5059991155			15.5 mm
	5059991160			16.0 mm
	5059991165			16.5 mm
	5059991170			17.0 mm
	5059991175			17.5 mm
	5059991180			18.0 mm
	5059991185			18.5 mm
	5059991190			19.0 mm
	5059991195			19.5 mm
	5059991200			20.0 mm
	5059991205			20.5 mm
	5059991210			21.0 mm
	5059991215			21.5 mm
	5059991220			22.0 mm
	5059991225			22.5 mm
	5059991230			23.0 mm
	5059991235			23.5 mm
	5059991240			24.0 mm
	5059991245			24.5 mm
	5059991250			25.0 mm
	5059991255			25.5 mm
	5059991260			26.0 mm
	5059991265			26.5 mm
	5059991270			27.0 mm
	5059991275			27.5 mm
	5059991280			28.0 mm
	5059991290			29.0 mm
	5059991300			30.0 mm



**Vierkantstempel Nr. 5**

**Square Punch No. 5**

**Code 50599 9 2**

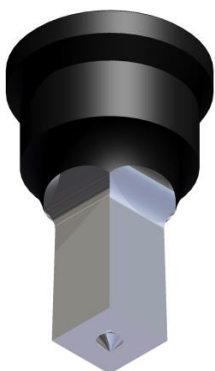

(0) 7854 – 8 77 38 20  
 +49 (0) 7854 – 8 77 38 21  
 Telefax: +49 (0) 7854 – 8 77 38 49

Menge	Artikelnummer	Abmessung
	5059992040	4.0 mm
	5059992050	5.0 mm
	5059992060	6.0 mm
	5059992070	7.0 mm
	5059992080	8.0 mm
	5059992090	9.0 mm
	5059992100	10.0 mm
	5059992110	11.0 mm
	5059992120	12.0 mm
	5059992130	13.0 mm
	5059992140	14.0 mm
	5059992150	15.0 mm
	5059992160	16.0 mm
	5059992170	17.0 mm
	5059992180	18.0 mm
	5059992190	19.0 mm

e-mail: [info@kewema.de](mailto:info@kewema.de)  
 Internet: [www.kewema.de](http://www.kewema.de)

	5059992200	20.0 mm
	5059992210	21.0 mm
	5059992220	22.0 mm

**Langlochstempel Nr. 5**

**Oblong Punch No. 5**

**Code 50599 9 3**

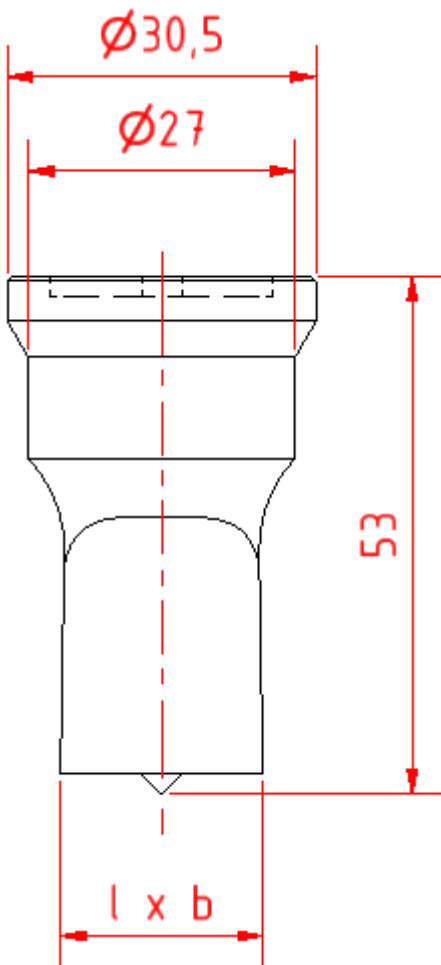

Menge	Artikelnummer	Abmessung
	5059993010	5.0 x 10.0 mm
	5059993015	5.0 x 14.0 mm
	5059993020	5.5 x 10.0 mm
	5059993025	5.5 x 14.0 mm
	5059993030	5.5 x 19.0 mm
	5059993035	5.5 x 25.0 mm
	5059993040	6.5 x 12.0 mm
	5059993045	6.5 x 18.0 mm
	5059993050	6.5 x 26.0 mm
	5059993055	7.5 x 14.0 mm
	5059993060	7.5 x 21.0 mm
	5059993065	7.5 x 26.0 mm
	5059993070	8.0 x 16.0 mm
	5059993075	9.0 x 14.0 mm
	5059993080	9.0 x 18.0 mm
	5059993085	9.0 x 26.0 mm
	5059993090	10.0 x 14.0 mm
	5059993095	10.0 x 20.0 mm
	5059993100	10.0 x 26.0 mm
	5059993105	11.0 x 22.0 mm
	5059993110	11.0 x 26.0 mm
	5059993115	12.0 x 24.0 mm
	5059993120	13.0 x 26.0 mm
	5059993125	14.0 x 26.0 mm
	5059993130	15.0 x 26.0 mm
	5059993135	16.0 x 26.0 mm
	5059993140	17.0 x 26.0 mm
	5059993145	18.0 x 26.0 mm
	5059993150	19.0 x 26.0 mm

**Exzenter-Rundstempel Nr. 5**

**Offset-Round Punch No. 5**

**Code 50599 9 3**

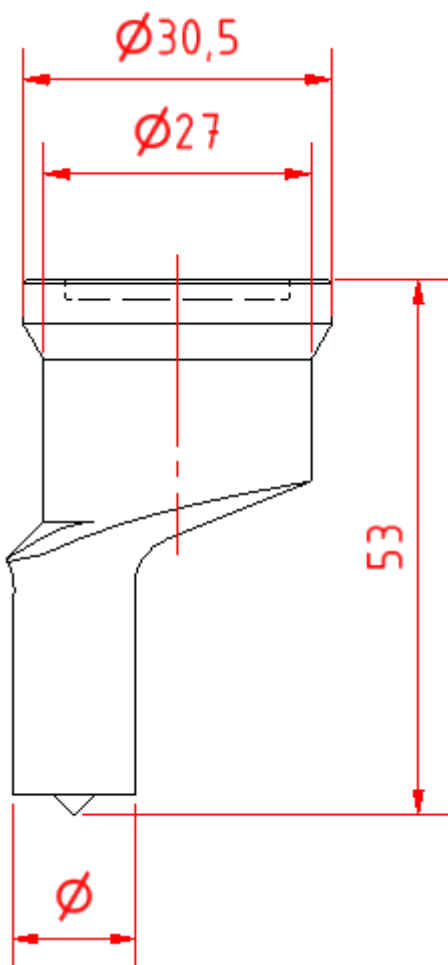
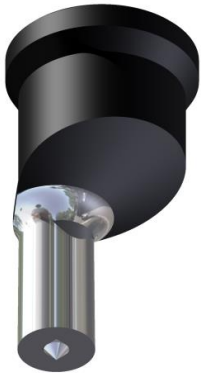

Menge	Artikelnummer	Abmessung
	5059998040	4.0 mm
	5059998050	5.0 mm
	5059998060	6.0 mm
	5059998070	7.0 mm
	5059998080	8.0 mm
	5059998090	9.0 mm
	5059998100	10.0 mm
	5059998110	11.0 mm
	5059998120	12.0 mm
	5059998130	13.0 mm
	5059998140	14.0 mm
	5059998150	15.0 mm

**Rundstempel Nr. 8/31**

**Round Punch No. 8/31**

**Code 50599 7 1**

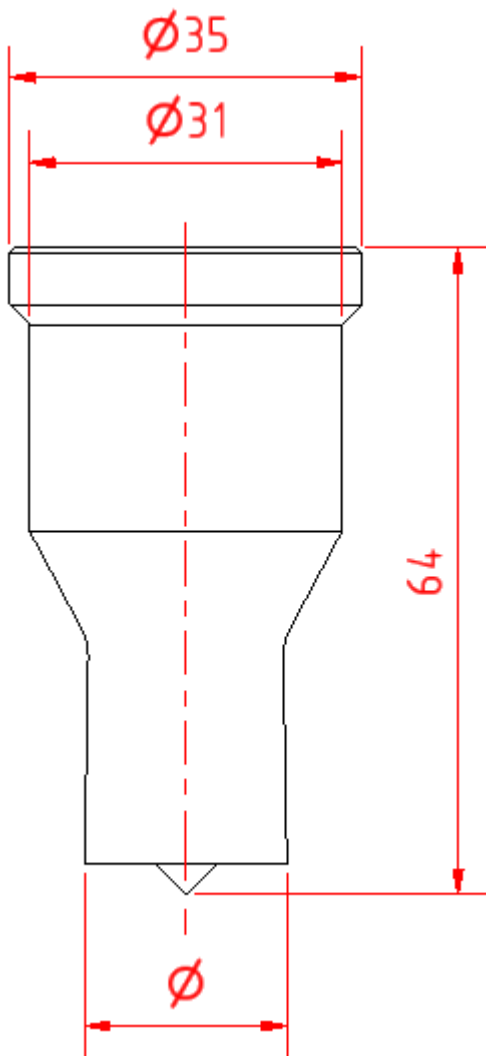

Menge	Artikelnummer	Abmessung
	5059971030	3.0 mm
	5059971035	3.5 mm
	5059971040	4.0 mm
	5059971045	4.5 mm
	5059971050	5.0 mm
	5059971055	5.5 mm
	5059971060	6.0 mm
	5059971065	6.5 mm
	5059971070	7.0 mm
	5059971075	7.5 mm
	5059971080	8.0 mm
	5059971085	8.5 mm
	5059971090	9.0 mm
	5059971095	9.5 mm
	5059971100	10.0 mm
	5059971105	10.5 mm
	5059971110	11.0 mm
	5059971115	11.5 mm
	5059971120	12.0 mm
	5059971125	12.5 mm
	5059971130	13.0 mm
	5059971135	13.5 mm
	5059971140	14.0 mm
	5059971145	14.5 mm
	5059971150	15.0 mm
	5059971155	15.5 mm
	5059971160	16.0 mm
	5059971165	16.5 mm
	5059971170	17.0 mm
	5059971175	17.5 mm
	5059971180	18.0 mm
	5059971185	18.5 mm
	5059971190	19.0 mm
	5059971195	19.5 mm
	5059971200	20.0 mm
	5059971205	20.5 mm
	5059971210	21.0 mm
	5059971215	21.5 mm
	5059971220	22.0 mm
	5059971225	22.5 mm
	5059971230	23.0 mm
	5059971235	23.5 mm
	5059971240	24.0 mm
	5059971245	24.5 mm
	5059971250	25.0 mm
	5059971255	25.5 mm
	5059971260	26.0 mm
	5059971265	26.5 mm
	5059971270	27.0 mm
	5059971275	27.5 mm
	5059971280	28.0 mm
	5059971285	28.5 mm
	5059971290	29.0 mm
	5059971295	29.5 mm
	5059971300	30.0 mm
	5059971305	30.5 mm
	5059971310	31.0 mm

**Vierkantstempel Nr. 8/31**

**Square Punch No. 8/31**

**Code 50599 7 2**

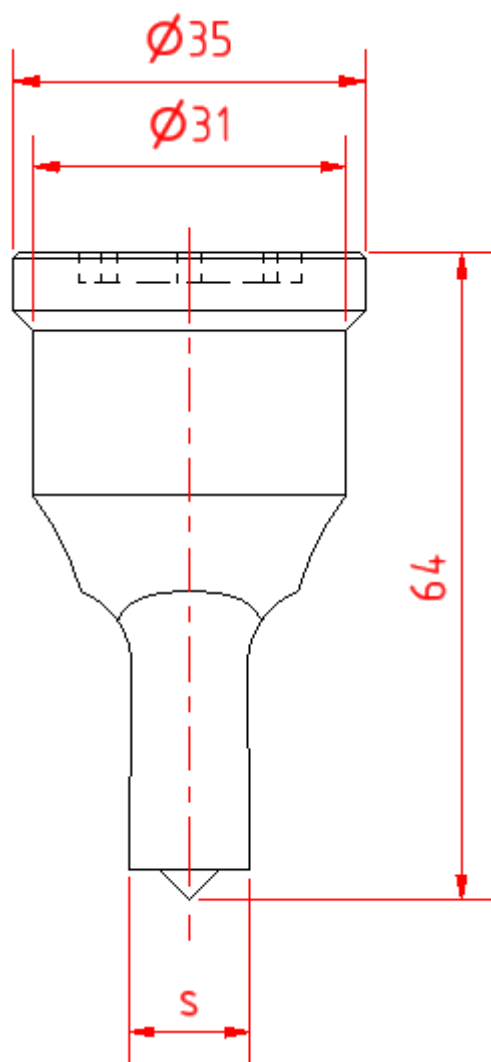
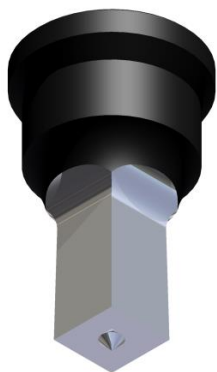

Menge	Artikelnummer	Abmessung
	5059972040	4.0 mm
	5059972050	5.0 mm
	5059972060	6.0 mm
	5059972070	7.0 mm
	5059972080	8.0 mm
	5059972090	9.0 mm
	5059972100	10.0 mm
	5059972110	11.0 mm
	5059972120	12.0 mm
	5059972130	13.0 mm
	5059972140	14.0 mm
	5059972150	15.0 mm
	5059972160	16.0 mm
	5059972170	17.0 mm
	5059972180	18.0 mm
	5059972190	19.0 mm
	5059972200	20.0 mm
	5059972210	21.0 mm
	5059972220	22.0 mm

**Langlochstempel Nr. 8/31**

**Oblong Punch No. 8/31**

**Code 50599 7 3**

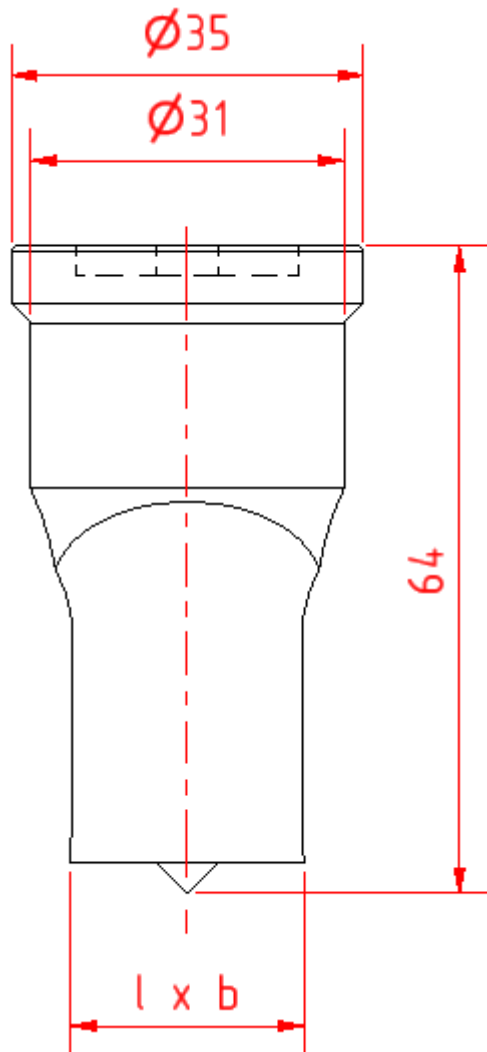

Menge	Artikelnummer	Abmessung
	5059973010	5.0 x 10.0 mm
	5059973020	5.0 x 14.0 mm
	5059973030	5.5 x 14.0 mm
	5059973040	5.5 x 19.0 mm
	5059973050	5.5 x 25.0 mm
	5059973060	6.5 x 12.0 mm
	5059973070	6.5 x 18.0 mm
	5059973080	6.5 x 26.0 mm
	5059973090	6.5 x 30.0 mm
	5059973100	7.5 x 14.0 mm
	5059973110	7.5 x 21.0 mm
	5059973120	7.5 x 26.0 mm
	5059973130	7.5 x 30.0 mm
	5059973140	8.0 x 16.0 mm
	5059973150	9.0 x 14.0 mm
	5059973160	9.0 x 18.0 mm
	5059973170	9.0 x 26.0 mm
	5059973180	9.0 x 30.0 mm
	5059973190	10.0 x 14.0 mm
	5059973200	10.0 x 20.0 mm
	5059973210	10.0 x 26.0 mm
	5059973220	10.0 x 30.0 mm
	5059973230	11.0 x 22.0 mm
	5059973240	11.0 x 26.0 mm
	5059973250	11.0 x 30.0 mm
	5059973260	12.0 x 24.0 mm
	5059973270	12.0 x 30.0 mm
	5059973280	13.0 x 26.0 mm
	5059973290	13.0 x 30.0 mm
	5059973300	14.0 x 26.0 mm
	5059973310	14.0 x 31.0 mm
	5059973320	15.0 x 26.0 mm
	5059973330	15.0 x 31.0 mm
	5059973340	16.0 x 26.0 mm
	5059973350	16.0 x 31.0 mm
	5059973360	17.0 x 26.0 mm
	5059973370	17.0 x 31.0 mm
	5059973380	18.0 x 26.0 mm
	5059973390	18.0 x 31.0 mm
	5059973400	19.0 x 26.0 mm
	5059973410	19.0 x 31.0 mm
	5059973420	20.0 x 31.0 mm
	5059973430	21.0 x 31.0 mm
	5059973440	22.0 x 31.0 mm

**Exzenter-Rundstempel Nr. 8/31**

**Offset-Round Punch No. 8/31**

**Code 50599 7 8**

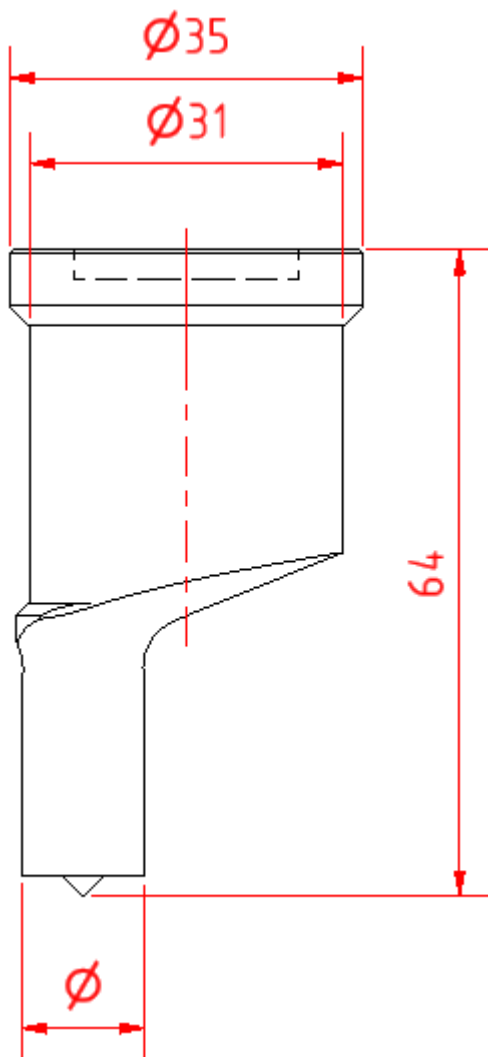
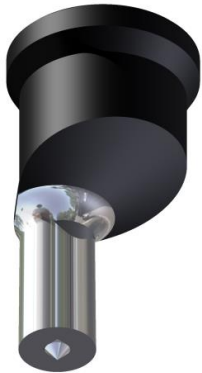

Menge	Artikelnummer	Abmessung
	5059978040	4.0 mm
	5059978050	5.0 mm
	5059978060	6.0 mm
	5059978070	7.0 mm
	5059978080	8.0 mm
	5059978090	9.0 mm
	5059978100	10.0 mm
	5059978110	11.0 mm
	5059978120	12.0 mm
	5059978130	13.0 mm
	5059978140	14.0 mm
	5059978150	15.0 mm

**Rundstempel Nr. 8/40**

**Round Punch No. 8/40**

**Code 50599 8 1**

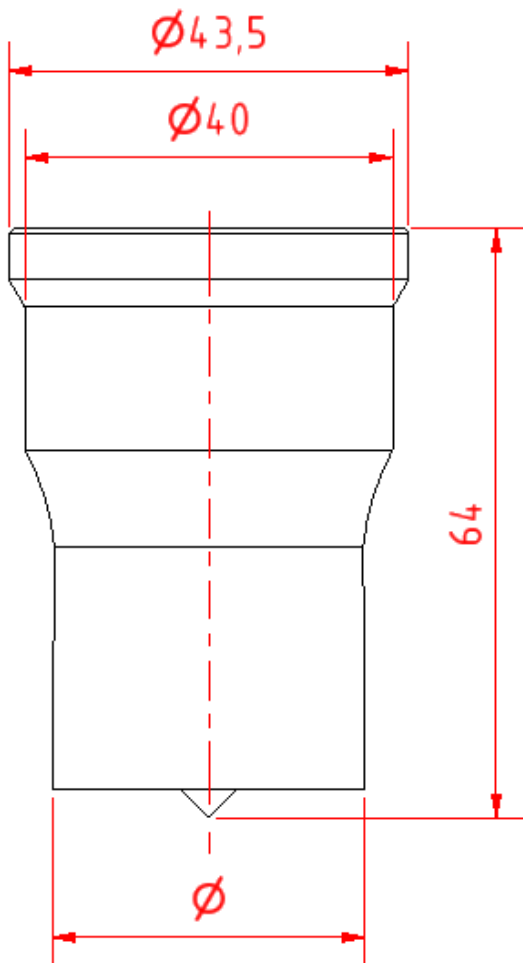

Menge	Artikelnummer	Abmessung
	5059981122	28.5 mm
	5059981124	29.0 mm
	5059981126	29.5 mm
	5059981128	30.0 mm
	5059981131	30.5 mm
	5059981133	31.0 mm
	5059981135	31.5 mm
	5059981137	32.0 mm
	5059981139	32.5 mm
	5059981142	33.0 mm
	5059981144	33.5 mm
	5059981146	34.0 mm
	5059981148	34.5 mm
	5059981151	35.0 mm
	5059981153	35.5 mm
	5059981155	36.0 mm
	5059981157	36.5 mm
	5059981159	37.0 mm
	5059981162	37.5 mm
	5059981164	38.0 mm
	5059981166	38.5 mm
	5059981168	39.0 mm
	5059981171	39.5 mm
	5059981173	40.0 mm

**Vierkantstempel Nr. 8/40**

**Square Punch No. 8/40**

**Code 50599 8 2**

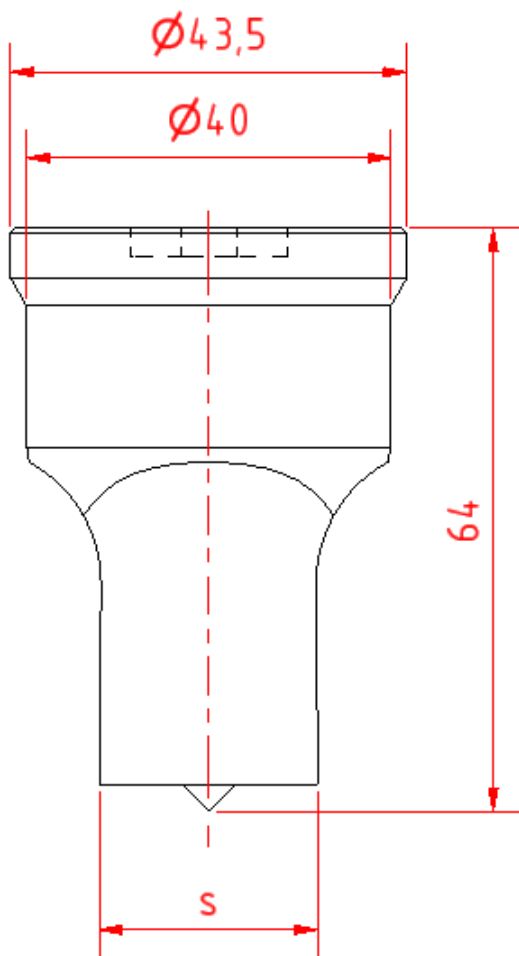
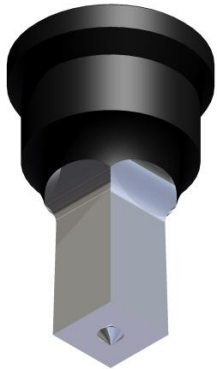

Menge	Artikelnummer	Abmessung
	5059982202	22.0 mm
	5059982206	23.0 mm
	5059982212	24.0 mm
	5059982216	25.0 mm
	5059982222	26.0 mm
	5059982226	27.0 mm
	5059982232	28.0 mm

**Langlochstempel Nr. 8/40**

**Oblong Punch No. 8/40**

**Code 50599 8 3**

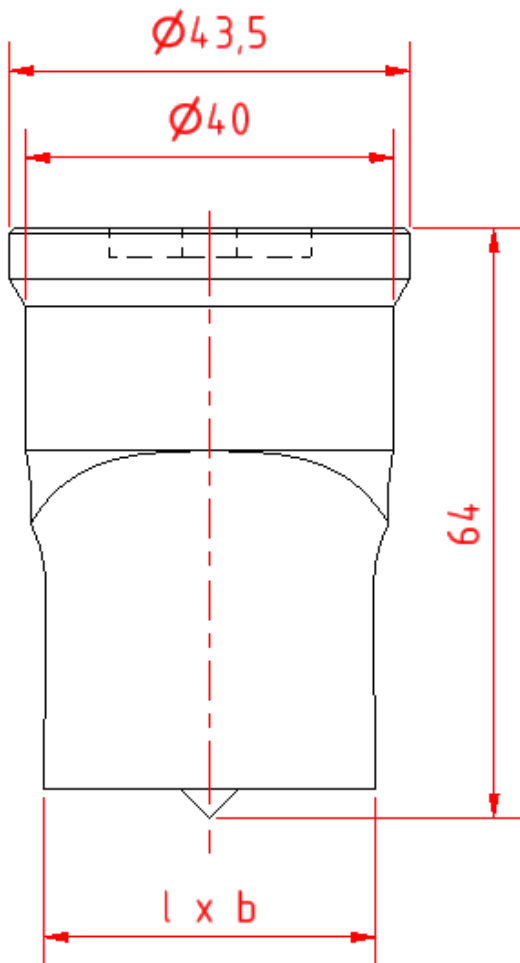

Menge	Artikelnummer	Abmessung
	5059983040	9.0 x 40.0 mm
	5059983045	10.0 x 40.0 mm
	5059983047	11.0 x 30.0 mm
	5059983171	11.0 x 40.0 mm
	5059983051	12.0 x 30.0 mm
	5059983052	12.0 x 35.0 mm
	5059983173	12.0 x 40.0 mm
	5059983055	13.0 x 30.0 mm
	5059983175	13.0 x 40.0 mm
	5059983056	13.5 x 35.0 mm
	5059983060	14.0 x 35.0 mm
	5059983177	14.0 x 40.0 mm
	5059983178	15.0 x 40.0 mm
	5059983063	16.0 x 31.0 mm
	5059983179	16.0 x 40.0 mm
	5059983181	17.0 x 40.0 mm
	5059983067	18.0 x 31.0 mm
	5059983068	18.0 x 36.0 mm
	5059983183	18.0 x 40.0 mm
	5059983185	19.0 x 40.0 mm
	5059983069	20.0 x 31.0 mm
	5059983187	20.0 x 40.0 mm
	5059983188	21.0 x 40.0 mm
	5059983191	22.0 x 40.0 mm
	5059983195	24.0 x 40.0 mm
	5059983200	26.0 x 40.0 mm

**Rundstempel Nr. 11**

**Round Punch No. 11**

**Code 50599 3 1**

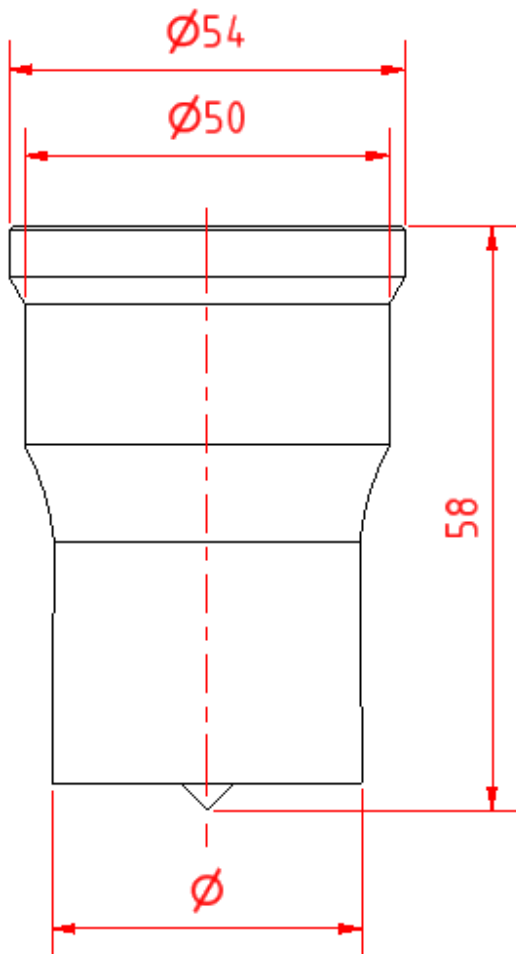

Menge	Artikelnummer	Abmessung
	5059931119	28.0 mm
	5059931122	28.5 mm
	5059931124	29.0 mm
	5059931126	29.5 mm
	5059931128	30.0 mm
	5059931131	30.5 mm
	5059931133	31.0 mm
	5059931137	32.0 mm
	5059931142	33.0 mm
	5059931146	34.0 mm
	5059931151	35.0 mm
	5059931155	36.0 mm
	5059931159	37.0 mm
	5059931164	38.0 mm
	5059931168	39.0 mm
	5059931173	40.0 mm
	5059931177	41.0 mm
	5059931182	42.0 mm
	5059931184	42.5 mm
	5059931186	43.0 mm
	5059931191	44.0 mm
	5059931195	45.0 mm
	5059931199	46.0 mm
	5059931204	47.0 mm
	5059931208	48.0 mm
	5059931213	49.0 mm
	5059931217	50.0 mm

**Vierkantstempel Nr. 11**

**Square Punch No. 11**

**Code 50599 3 2**

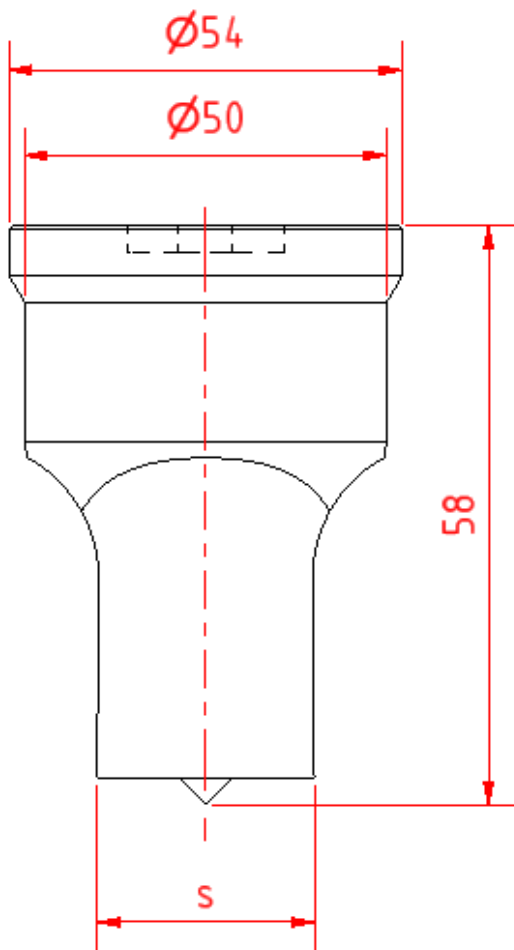
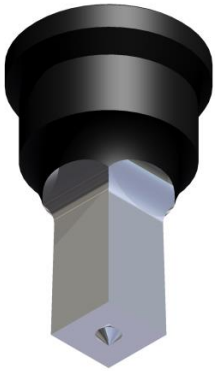

Menge	Artikelnummer	Abmessung
	5059932192	20.0 mm
	5059932196	21.0 mm
	5059932202	22.0 mm
	5059932206	23.0 mm
	5059932212	24.0 mm
	5059932216	25.0 mm
	5059932222	26.0 mm
	5059932226	27.0 mm
	5059932232	28.0 mm
	5059932236	29.0 mm
	5059932242	30.0 mm
	5059932246	31.0 mm
	5059932252	32.0 mm
	5059932256	33.0 mm
	5059932262	34.0 mm
	5059932266	35.0 mm

**Langlochstempel Nr. 11**

**Oblong Punch No. 11**

**Code 50599 3 3**

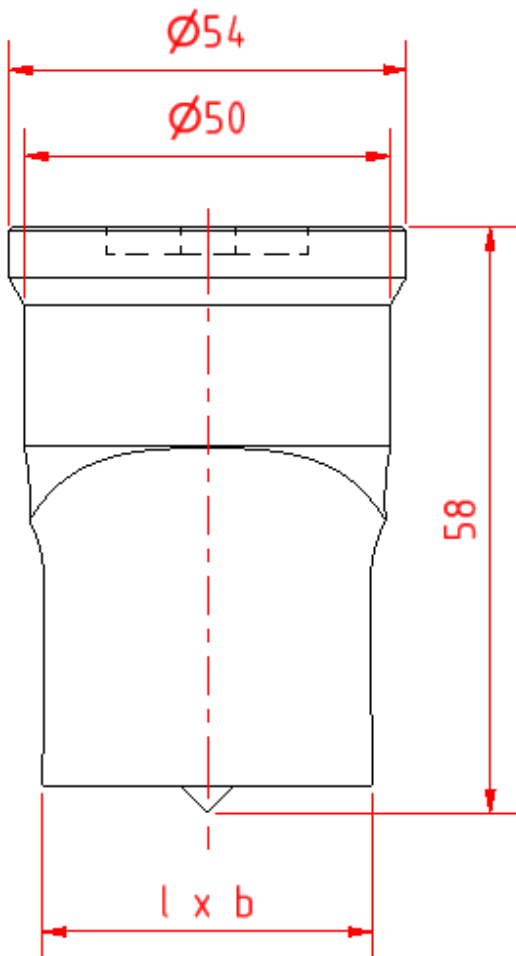

Menge	Artikelnummer	Abmessung
	5059933043	10.0 x 45.0 mm
	5059933044	10.0 x 50.0 mm
	5059933049	11.0 x 45.0 mm
	5059933050	11.0 x 50.0 mm
	5059933053	12.0 x 45.0 mm
	5059933054	12.0 x 50.0 mm
	5059933057	13.0 x 45.0 mm
	5059933058	13.0 x 50.0 mm
	5059933061	14.0 x 45.0 mm
	5059933062	14.0 x 50.0 mm
	5059933064	16.0 x 45.0 mm
	5059933065	16.0 x 50.0 mm
	5059933184	18.0 x 45.0 mm
	5059933185	18.0 x 50.0 mm
	5059933188	20.0 x 45.0 mm
	5059933189	20.0 x 50.0 mm
	5059933193	22.0 x 45.0 mm
	5059933195	22.0 x 50.0 mm

**Rundstempel Nr. 12**

**Round Punch No. 12**

**Code 50599 4 1**

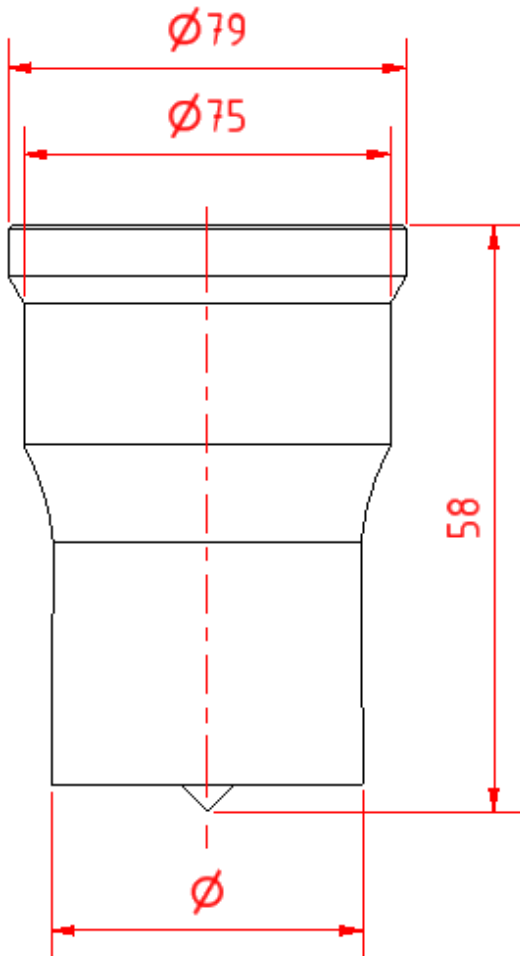

Menge	Artikelnummer	Abmessung
	5059941222	51.0 mm
	5059941226	52.0 mm
	5059941235	54.0 mm
	5059941238	55.0 mm
	5059941244	56.0 mm
	5059941253	58.0 mm
	5059941257	59.0 mm
	5059941262	60.0 mm
	5059941266	61.0 mm
	5059941271	62.0 mm
	5059941279	64.0 mm
	5059941283	65.0 mm
	5059941288	66.0 mm
	5059941302	68.0 mm
	5059941311	70.0 mm
	5059941319	72.0 mm
	5059941328	74.0 mm
	5059941330	75.0 mm

**Vierkantstempel Nr. 12**

**Square Punch No. 12**

**Code 50599 4 2**

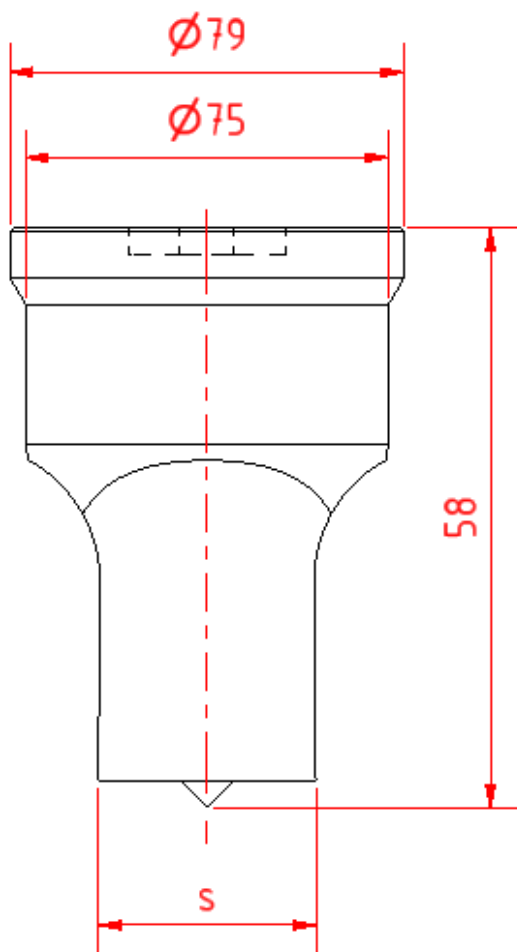
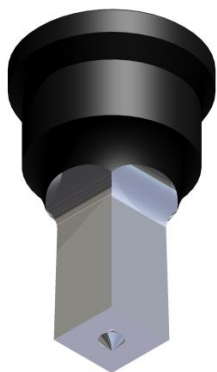

Menge	Artikelnummer	Abmessung
	5059942303	40.0 mm
	5059942305	45.0 mm
	5059942307	50.0 mm

**Langlochstempel Nr. 12**

**Oblong Punch No. 12**

**Code 50599 4 3**

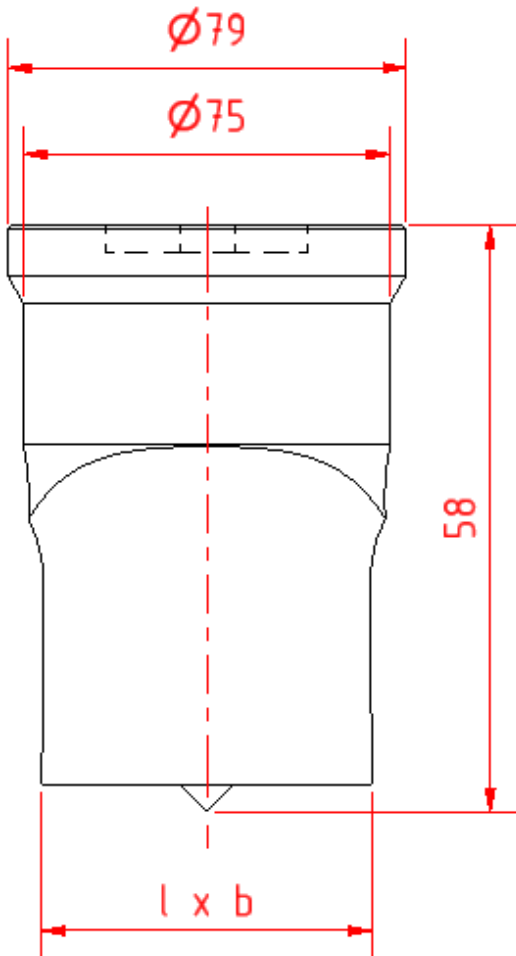

Menge	Artikelnummer	Abmessung
	5059943160	10.0 x 55.0 mm
	5059943164	10.0 x 75.0 mm
	5059943165	11.0 x 55.0 mm
	5059943166	11.0 x 75.0 mm
	5059943168	12.0 x 55.0 mm
	5059943170	12.0 x 75.0 mm
	5059943175	13.0 x 55.0 mm
	5059943177	13.0 x 75.0 mm
	5059943179	14.0 x 55.0 mm
	5059943180	14.0 x 75.0 mm
	5059943181	16.0 x 55.0 mm
	5059943183	16.0 x 75.0 mm
	5059943185	18.0 x 55.0 mm
	5059943188	18.0 x 75.0 mm
	5059943189	20.0 x 55.0 mm
	5059943191	20.0 x 75.0 mm
	5059943193	22.0 x 55.0 mm
	5059943197	22.0 x 75.0 mm

**Rundstempel Nr. 13**

**Round Punch No. 13**

**Code 50599 5 1**

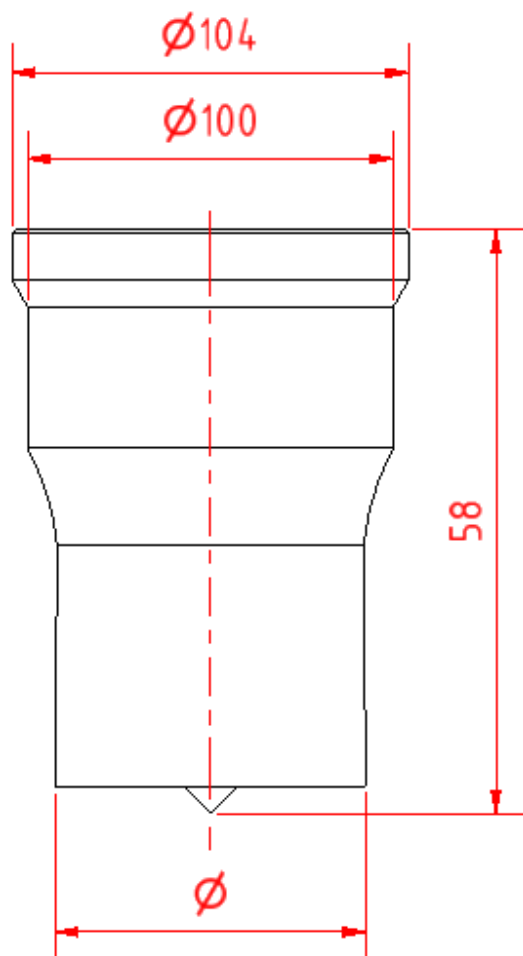

Menge	Artikelnummer	Abmessung
	5059951337	76.0 mm
	5059951342	77.0 mm
	5059951346	78.0 mm
	5059951355	80.0 mm
	5059951364	82.0 mm
	5059951373	84.0 mm
	5059951377	85.0 mm
	5059951382	86.0 mm
	5059951391	88.0 mm
	5059951399	90.0 mm
	5059951408	92.0 mm
	5059951417	94.0 mm
	5059951420	95.0 mm
	5059951426	96.0 mm
	5059951435	98.0 mm
	5059951446	100.0 mm

**Vierkantstempel Nr. 13**

**Square Punch No. 13**

**Code 50599 5 2**

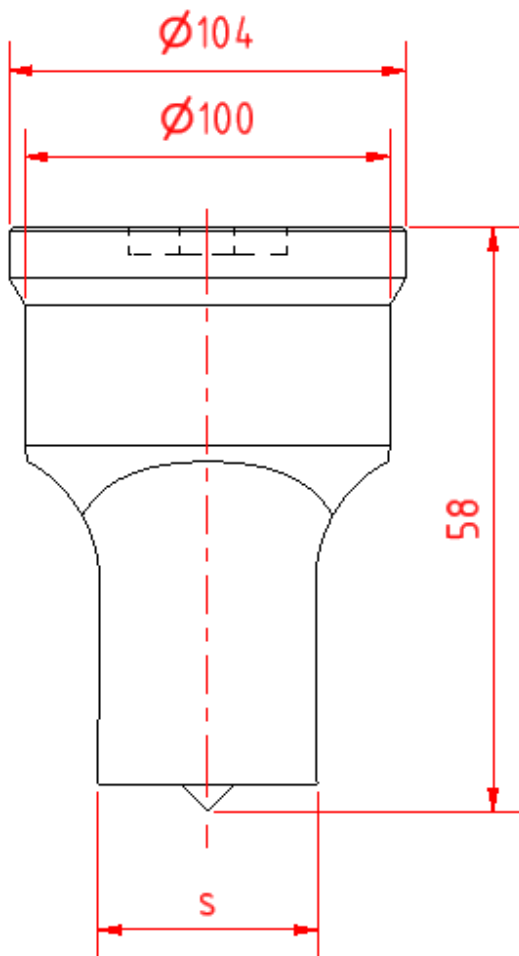
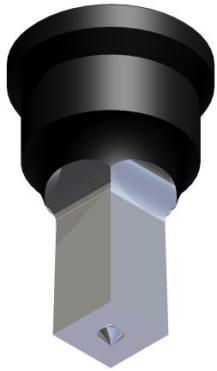

Menge	Artikelnummer	Abmessung
	5059952311	55.0 mm
	5059952313	60.0 mm
	5059952315	65.0 mm
	5059952317	70.0 mm

**Langlochstempel Nr. 13**

**Oblong Punch No. 13**

**Code 50599 5 3**

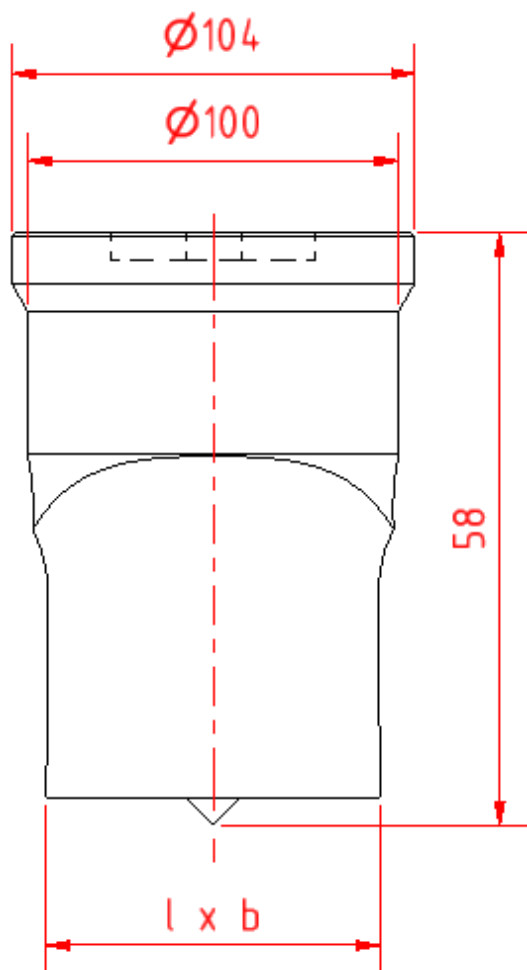

Menge	Artikelnummer	Abmessung
-------	---------------	-----------

\*auf Anfrage / on demand

**Rundstempel Nr. 5 EA**

**Round Punch No. 5 EA**

**Code 50599 9 1**

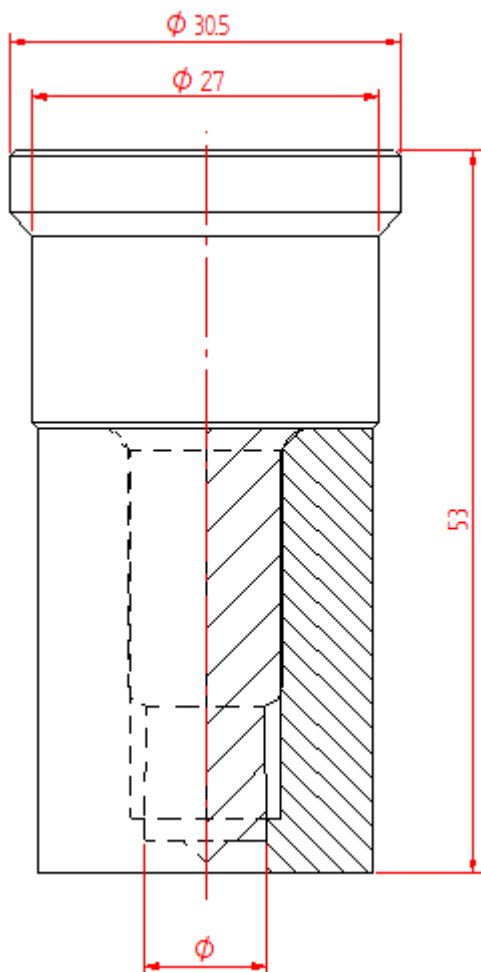

Menge	Artikelnummer	Abmessung
-------	---------------	-----------

\*auf Anfrage / on demand

**Rundstempel Nr. 8/31 EA**

**Round Punch No. 8/31 EA**

**Code 50599 7 1**

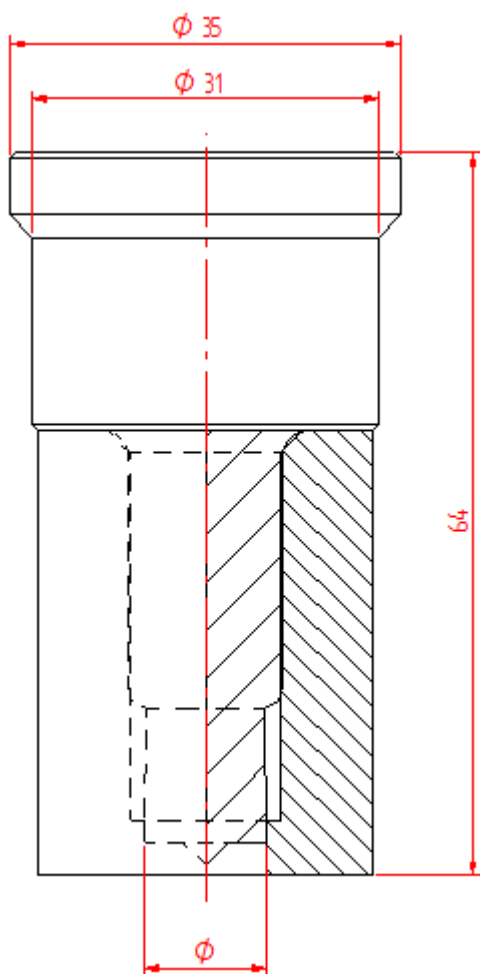

Menge	Artikelnummer	Abmessung
-------	---------------	-----------

\*auf Anfrage / on demand

**Rundstempel Nr. 8/40 EA**

**Round Punch No. 8/40 EA**

**Code 50599 8 1**

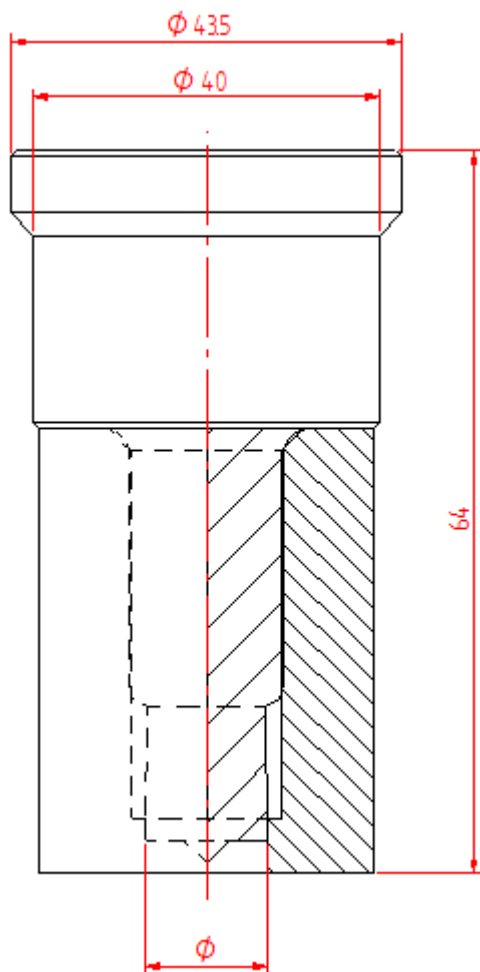

Menge	Artikelnummer	Abmessung
-------	---------------	-----------

\*auf Anfrage / on demand

**Rundmatrize Nr. 5**

**Round Die No. 5**

**Code 50695 6 1**

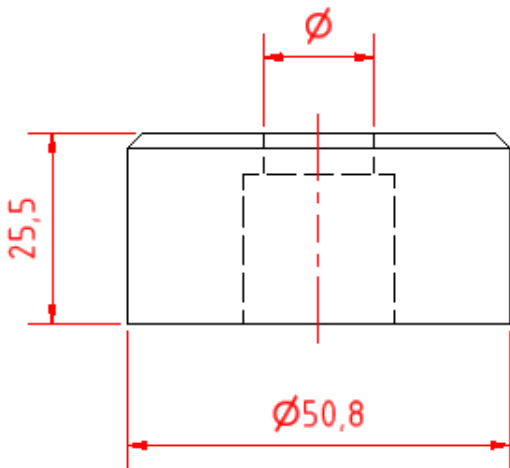
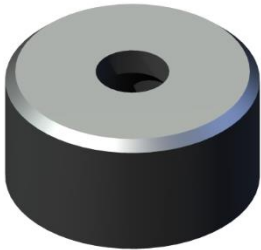

Menge	Artikelnummer	Abmessung
	5069561032	3.2 mm
	5069561037	3.7 mm
	5069561042	4.2 mm
	5069561047	4.7 mm
	5069561052	5.2 mm
	5069561057	5.7 mm
	5069561062	6.2 mm
	5069561067	6.7 mm
	5069561072	7.2 mm
	5069561077	7.7 mm
	5069561082	8.2 mm
	5069561087	8.7 mm
	5069561092	9.2 mm
	5069561097	9.7 mm
	5069561102	10.2 mm
	5069561107	10.7 mm
	5069561112	11.2 mm
	5069561117	11.7 mm
	5069561122	12.2 mm
	5069561127	12.7 mm
	5069561132	13.2 mm
	5069561137	13.7 mm
	5069561142	14.2 mm
	5069561147	14.7 mm
	5069561152	15.2 mm
	5069561157	15.7 mm
	5069561162	16.2 mm
	5069561167	16.7 mm
	5069561172	17.2 mm
	5069561177	17.7 mm
	5069561182	18.2 mm
	5069561187	18.7 mm
	5069561192	19.2 mm
	5069561197	19.7 mm
	5069561202	20.2 mm
	5069561207	20.7 mm
	5069561212	21.2 mm
	5069561217	21.7 mm
	5069561222	22.2 mm
	5069561227	22.7 mm
	5069561232	23.2 mm
	5069561237	23.7 mm
	5069561242	24.2 mm
	5069561247	24.7 mm
	5069561252	25.2 mm
	5069561257	25.7 mm
	5069561262	26.2 mm
	5069561267	26.7 mm
	5069561272	27.2 mm
	5069561277	27.7 mm
	5069561282	28.2 mm
	5069561287	28.7 mm
	5069561292	29.2 mm
	5069561297	29.7 mm
	5069561302	30.2 mm
	5069561307	30.7 mm
	5069561312	31.2 mm
	5069561317	31.7 mm
	5069561322	32.2 mm
	5069561327	32.7 mm
	5069561332	33.2 mm

**Vierkantmatrize Nr. 5**

**Square Die No. 5**

**Code 50695 6 2**

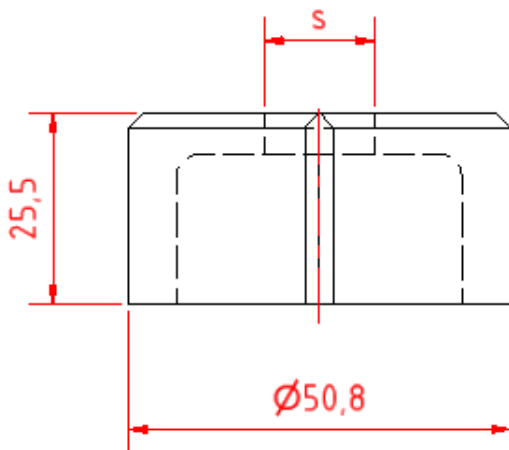
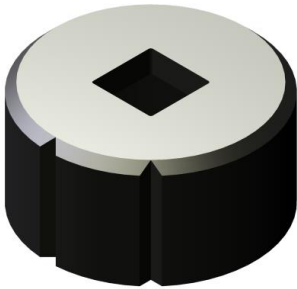

Menge	Artikelnummer	Abmessung
	5069562042	4.2 mm
	5069562047	4.7 mm
	5069562052	5.2 mm
	5069562057	5.7 mm
	5069562062	6.2 mm
	5069562067	6.7 mm
	5069562072	7.2 mm
	5069562077	7.7 mm
	5069562082	8.2 mm
	5069562087	8.7 mm
	5069562092	9.2 mm
	5069562097	9.7 mm
	5069562098	10.2 mm
	5069562107	10.7 mm
	5069562163	11.2 mm
	5069562117	11.7 mm
	5069562122	12.2 mm
	5069562127	12.7 mm
	5069562164	13.2 mm
	5069562137	13.7 mm
	5069562142	14.2 mm
	5069562147	14.7 mm
	5069562102	15.2 mm
	5069562157	15.7 mm
	5069562162	16.2 mm
	5069562167	16.7 mm
	5069562176	17.2 mm
	5069562177	17.7 mm
	5069562182	18.2 mm
	5069562187	18.7 mm
	5069562099	19.2 mm
	5069562197	19.7 mm
	5069562202	20.2 mm
	5069562207	20.7 mm
	5069562101	21.2 mm
	5069562217	21.7 mm
	5069562222	22.2 mm
	5069562227	22.7 mm

**Langlochmatrize Nr. 5**

**Oblong Die No. 5**

**Code 50695 6 3**

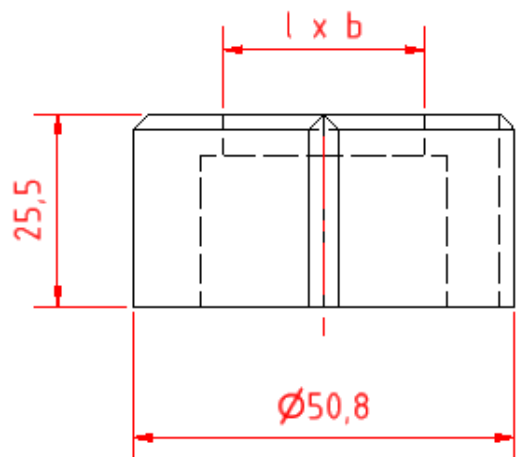
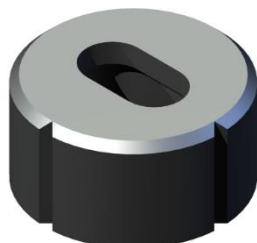

Menge	Artikelnummer	Abmessung	Menge	Artikelnummer	Abmessung
	5069563005	5.2 x 10.2 mm		5069563330	15.7 x 26.7 mm
	5069563015	5.2 x 14.2 mm		5069563340	15.7 x 31.7 mm
	5069563025	5.7 x 10.2 mm		5069563345	16.2 x 26.2 mm
	5069563010	5.7 x 10.7 mm		5069563355	16.2 x 31.2 mm
	5069563035	5.7 x 14.2 mm		5069563350	16.7 x 26.7 mm
	5069563020	5.7 x 14.7 mm		5069563360	16.7 x 31.7 mm
	5069563045	5.7 x 19.2 mm		5069563365	17.2 x 26.2 mm
	5069563055	5.7 x 25.2 mm		5069563375	17.2 x 31.2 mm
	5069563030	6.2 x 10.7 mm		5069563370	17.7 x 26.7 mm
	5069563040	6.2 x 14.7 mm		5069563380	17.7 x 31.7 mm
	5069563050	6.2 x 19.7 mm		5069563385	18.2 x 26.2 mm
	5069563060	6.2 x 25.7 mm		5069563395	18.2 x 31.2 mm
	5069563065	6.7 x 12.2 mm		5069563390	18.7 x 26.7 mm
	5069563075	6.7 x 18.2 mm		5069563400	18.7 x 31.7 mm
	5069563085	6.7 x 26.2 mm		5069563405	19.2 x 26.2 mm
	5069563095	6.7 x 30.2 mm		5069563415	19.2 x 31.2 mm
	5069563070	7.2 x 12.7 mm		5069563410	19.7 x 26.7 mm
	5069563080	7.2 x 18.7 mm		5069563420	19.7 x 31.7 mm
	5069563090	7.2 x 26.7 mm		5069563425	20.2 x 31.2 mm
	5069563100	7.2 x 30.7 mm		5069563430	20.7 x 31.7 mm
	5069563105	7.7 x 14.2 mm		5069563445	21.2 x 31.2 mm
	5069563115	7.7 x 21.2 mm		5069563455	22.2 x 31.2 mm
	5069563125	7.7 x 26.2 mm		5069563460	22.7 x 31.7 mm
	5069563135	7.7 x 30.2 mm			
	5069563110	8.2 x 14.7 mm			
	5069563120	8.2 x 21.7 mm			
	5069563130	8.2 x 26.7 mm			
	5069563140	8.2 x 30.7 mm			
	5069563145	8.2 x 16.2 mm			
	5069563150	8.7 x 16.7 mm			
	5069563155	9.2 x 14.2 mm			
	5069563165	9.2 x 18.2 mm			
	5069563175	9.2 x 26.2 mm			
	5069563185	9.2 x 30.2 mm			
	5069563160	9.7 x 14.7 mm			
	5069563170	9.7 x 18.7 mm			
	5069563180	9.7 x 26.7 mm			
	5069563190	9.7 x 30.7 mm			
	5069563195	10.2 x 14.2 mm			
	5069563205	10.2 x 20.2 mm			
	5069563215	10.2 x 26.2 mm			
	5069563225	10.2 x 30.2 mm			
	5069563200	10.7 x 14.7 mm			
	5069563210	10.7 x 20.7 mm			
	5069563220	10.7 x 26.7 mm			
	5069563230	10.7 x 30.7 mm			
	5069563235	11.2 x 22.2 mm			
	5069563245	11.2 x 26.2 mm			
	5069563255	11.2 x 30.2 mm			
	5069563240	11.7 x 22.7 mm			
	5069563250	11.7 x 26.7 mm			
	5069563260	11.7 x 30.7 mm			
	5069563265	12.2 x 24.2 mm			
	5069563275	12.2 x 30.2 mm			
	5069563270	12.7 x 24.7 mm			
	5069563280	12.7 x 30.7 mm			
	5069563285	13.2 x 26.2 mm			
	5069563295	13.2 x 30.2 mm			
	5069563290	13.7 x 26.7 mm			
	5069563300	13.7 x 30.7 mm			
	5069563305	14.2 x 26.2 mm			
	5069563315	14.2 x 31.2 mm			
	5069563310	14.7 x 26.7 mm			
	5069563320	14.7 x 31.7 mm			

**Exzenter-Rundmatrize Nr. 5**

**Offset-Round Die No. 5**

**Code 50695 6 8**

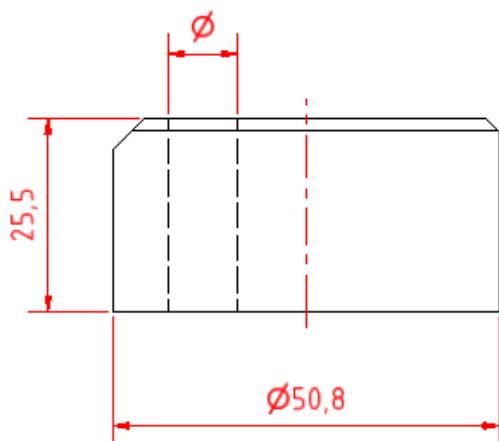
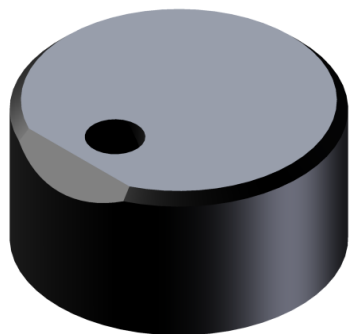

Menge	Artikelnummer	Abmessung
	5069568047	4.7 mm
	5069568057	5.7 mm
	5069568067	6.7 mm
	5069568077	7.7 mm
	5069568087	8.7 mm
	5069568097	9.7 mm
	5069568107	10.7 mm
	5069568117	11.7 mm
	5069568127	12.7 mm
	5069568137	13.7 mm
	5069568147	14.7 mm
	5069568157	15.7 mm

**Rundmatrize Nr. 8**

**Round Die No. 8**

**Code 50695 8 1**

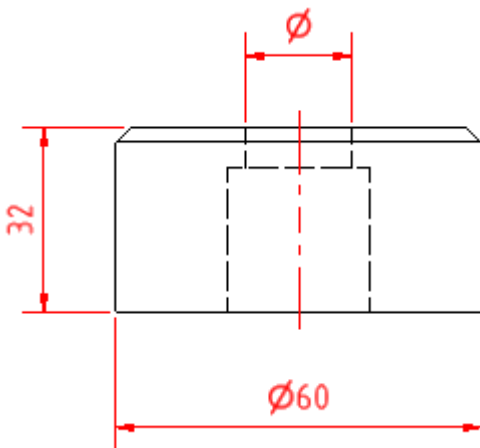
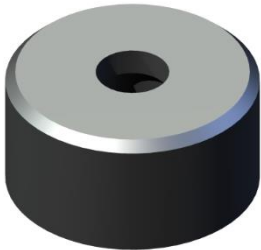

Menge	Artikelnummer	Abmessung	Menge	Artikelnummer	Abmessung
	5069581009	3.2 mm		5069581134	31.2 mm
	5069581012	3.7 mm		5069581136	31.7 mm
	5069581014	4.2 mm		5069581138	32.2 mm
	5069581016	4.7 mm		5069581141	32.7 mm
	5069581018	5.2 mm		5069581143	33.2 mm
	5069581021	5.7 mm		5069581145	33.7 mm
	5069581023	6.2 mm		5069581147	34.2 mm
	5069581025	6.7 mm		5069581149	34.7 mm
	5069581027	7.2 mm		5069581152	35.2 mm
	5069581029	7.7 mm		5069581154	35.7 mm
	5069581032	8.2 mm		5069581156	36.2 mm
	5069581034	8.7 mm		5069581158	36.7 mm
	5069581036	9.2 mm		5069581161	37.2 mm
	5069581038	9.7 mm		5069581163	37.7 mm
	5069581041	10.2 mm		5069581165	38.2 mm
	5069581043	10.7 mm		5069581167	38.7 mm
	5069581045	11.2 mm		5069581169	39.2 mm
	5069581047	11.7 mm		5069581172	39.7 mm
	5069581049	12.2 mm		5069581174	40.2 mm
	5069581052	12.7 mm		5069581176	40.7 mm
	5069581054	13.2 mm		5069581178	41.2 mm
	5069581056	13.7 mm			
	5069581058	14.2 mm			
	5069581061	14.7 mm			
	5069581063	15.2 mm			
	5069581065	15.7 mm			
	5069581067	16.2 mm			
	5069581069	16.7 mm			
	5069581072	17.2 mm			
	5069581074	17.7 mm			
	5069581076	18.2 mm			
	5069581078	18.7 mm			
	5069581081	19.2 mm			
	5069581083	19.7 mm			
	5069581085	20.2 mm			
	5069581087	20.7 mm			
	5069581089	21.2 mm			
	5069581092	21.7 mm			
	5069581094	22.2 mm			
	5069581096	22.7 mm			
	5069581098	23.2 mm			
	5069581101	23.7 mm			
	5069581103	24.2 mm			
	5069581105	24.7 mm			
	5069581107	25.2 mm			
	5069581109	25.7 mm			
	5069581112	26.2 mm			
	5069581114	26.7 mm			
	5069581116	27.2 mm			
	5069581118	27.7 mm			
	5069581121	28.2 mm			
	5069581123	28.7 mm			
	5069581125	29.2 mm			
	5069581127	29.7 mm			
	5069581129	30.2 mm			
	5069581132	30.7 mm			

**Vierkantmatrize Nr. 8**

**Square Die No. 8**

**Code 50695 8 2**

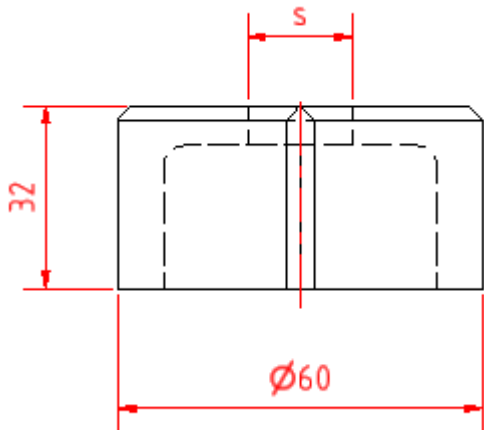
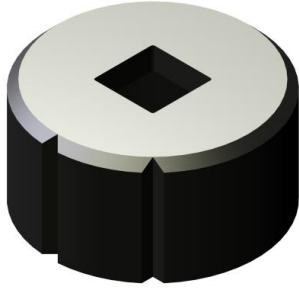

Menge	Artikelnummer	Abmessung
	5069582113	4.2 mm
	5069582115	4.7 mm
	5069582117	5.2 mm
	5069582121	5.7 mm
	5069582123	6.2 mm
	5069582125	6.7 mm
	5069582127	7.2 mm
	5069582131	7.7 mm
	5069582133	8.2 mm
	5069582135	8.7 mm
	5069582137	9.2 mm
	5069582141	9.7 mm
	5069582143	10.2 mm
	5069582145	10.7 mm
	5069582147	11.2 mm
	5069582151	11.7 mm
	5069582153	12.2 mm
	5069582155	12.7 mm
	5069582157	13.2 mm
	5069582161	13.7 mm
	5069582163	14.2 mm
	5069582165	14.7 mm
	5069582167	15.2 mm
	5069582171	15.7 mm
	5069582173	16.2 mm
	5069582175	16.7 mm
	5069582177	17.2 mm
	5069582181	17.7 mm
	5069582183	18.2 mm
	5069582185	18.7 mm
	5069582187	19.2 mm
	5069582191	19.7 mm
	5069582193	20.2 mm
	5069582195	20.7 mm
	5069582197	21.2 mm
	5069582201	21.7 mm
	5069582203	22.2 mm
	5069582205	22.7 mm
	5069582207	23.2 mm
	5069582211	23.7 mm
	5069582213	24.2 mm
	5069582215	24.7 mm
	5069582217	25.2 mm
	5069582221	25.7 mm
	5069582223	26.2 mm
	5069582225	26.7 mm
	5069582227	27.2 mm
	5069582231	27.7 mm
	5069582233	28.2 mm
	5069582235	28.7 mm

**Langlochmatrize Nr. 8**

**Oblong Die No. 8**

**Code 50695 8 3**

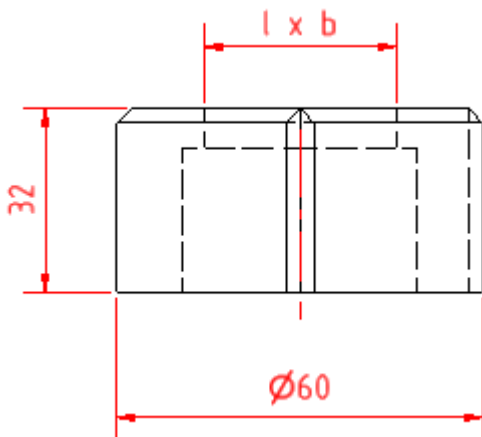
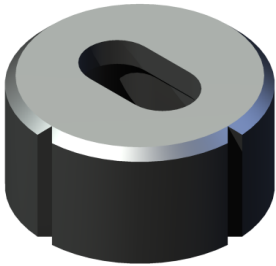

Menge	Artikelnummer	Abmessung	Menge	Artikelnummer	Abmessung
	5069583001	5.2 x 10.2 mm		5069583105	12.7 x 24.7 mm
	5069583005	5.2 x 14.2 mm		5069583109	12.7 x 30.7 mm
	5069583007	5.7 x 10.2 mm		5069583113	12.7 x 35.7 mm
	5069583003	5.7 x 10.7 mm		5069583174	12.7 x 40.7 mm
	5069583013	5.7 x 14.2 mm		5069583115	13.2 x 26.2 mm
	5069583006	5.7 x 14.7 mm		5069583119	13.2 x 30.2 mm
	5069583017	5.7 x 19.2 mm		5069583123	13.2 x 35.2 mm
	5069583021	5.7 x 25.2 mm		5069583175	13.2 x 40.2 mm
	5069583011	6.2 x 10.7 mm		5069583117	13.7 x 26.7 mm
	5069583015	6.2 x 14.7 mm		5069583121	13.7 x 30.7 mm
	5069583019	6.2 x 19.7 mm		5069583125	13.7 x 35.7 mm
	5069583023	6.2 x 25.7 mm		5069583176	13.7 x 40.7 mm
	5069583025	6.7 x 12.2 mm		5069583127	14.2 x 26.2 mm
	5069583029	6.7 x 18.2 mm		5069583131	14.2 x 28.2 mm
	5069583033	6.7 x 26.2 mm		5069583135	14.2 x 35.2 mm
	5069583037	6.7 x 30.2 mm		5069583177	14.2 x 40.2 mm
	5069583027	7.2 x 12.7 mm		5069583129	14.7 x 26.7 mm
	5069583031	7.2 x 18.7 mm		5069583133	14.7 x 28.7 mm
	5069583035	7.2 x 26.7 mm		5069583137	14.7 x 35.7 mm
	5069583039	7.2 x 30.7 mm		5069583178	14.7 x 40.7 mm
	5069583041	7.7 x 14.2 mm		5069583201	15.2 x 40.2 mm
	5069583045	7.7 x 21.2 mm		5069583202	15.7 x 40.7 mm
	5069583051	7.7 x 26.2 mm		5069583139	16.2 x 26.2 mm
	5069583055	7.7 x 30.2 mm		5069583143	16.2 x 31.2 mm
	5069583043	8.2 x 14.7 mm		5069583179	16.2 x 40.2 mm
	5069583047	8.2 x 21.7 mm		5069583141	16.7 x 26.7 mm
	5069583053	8.2 x 26.7 mm		5069583145	16.7 x 31.7 mm
	5069583057	8.2 x 30.7 mm		5069583180	16.7 x 40.7 mm
	5069583059	9.2 x 14.2 mm		5069583181	17.2 x 40.2 mm
	5069583063	9.2 x 18.2 mm		5069583182	17.7 x 40.7 mm
	5069583067	9.2 x 26.2 mm		5069583147	18.2 x 26.2 mm
	5069583071	9.2 x 30.2 mm		5069583151	18.2 x 31.2 mm
	5069583167	9.2 x 40.2 mm		5069583155	18.2 x 36.2 mm
	5069583061	9.7 x 14.7 mm		5069583183	18.2 x 40.2 mm
	5069583065	9.7 x 18.7 mm		5069583149	18.7 x 26.7 mm
	5069583069	9.7 x 26.7 mm		5069583153	18.7 x 31.7 mm
	5069583073	9.7 x 30.7 mm		5069583157	18.7 x 36.7 mm
	5069583168	9.7 x 40.7 mm		5069583184	18.7 x 40.7 mm
	5069583075	10.2 x 14.2 mm		5069583185	19.2 x 40.2 mm
	5069583079	10.2 x 20.2 mm		5069583186	19.7 x 40.7 mm
	5069583083	10.2 x 26.2 mm		5069583159	20.2 x 31.2 mm
	5069583087	10.2 x 30.2 mm		5069583187	20.2 x 40.2 mm
	5069583169	10.2 x 40.2 mm		5069583161	20.7 x 31.7 mm
	5069583077	10.7 x 14.7 mm		5069583188	20.7 x 40.7 mm
	5069583081	10.7 x 20.7 mm		5069583189	21.2 x 40.2 mm
	5069583085	10.7 x 26.7 mm		5069583190	21.7 x 40.7 mm
	5069583089	10.7 x 30.7 mm		5069583163	22.2 x 31.2 mm
	5069583170	10.7 x 40.7 mm		5069583191	22.2 x 40.2 mm
	5069583091	11.2 x 22.2 mm		5069583165	22.7 x 31.7 mm
	5069583095	11.2 x 26.2 mm		5069583192	22.7 x 40.7 mm
	5069583099	11.2 x 30.2 mm		5069583195	24.2 x 40.2 mm
	5069583171	11.2 x 40.2 mm		5069583196	24.7 x 40.7 mm
	5069583093	11.7 x 22.7 mm		5069583199	26.2 x 40.2 mm
	5069583097	11.7 x 26.7 mm		5069583200	26.7 x 40.7 mm
	5069583101	11.7 x 30.7 mm			
	5069583172	11.7 x 40.7 mm			
	5069583103	12.2 x 24.2 mm			
	5069583107	12.2 x 30.2 mm			
	5069583111	12.2 x 35.2 mm			
	5069583173	12.2 x 40.2 mm			

**Rundmatrize Nr. 11**

**Round Die No. 11**

**Code 50695 4 1**

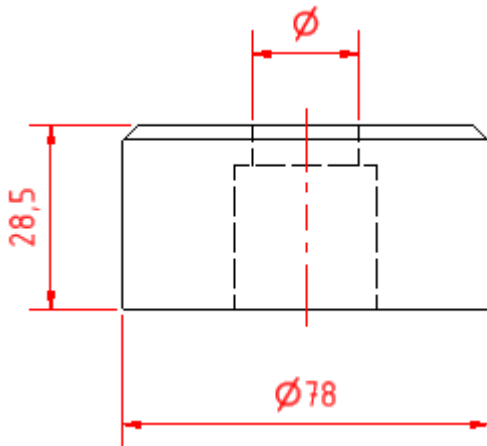
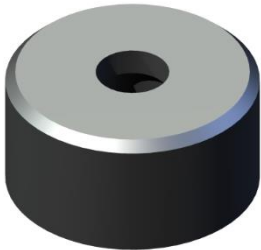

Menge	Artikelnummer	Abmessung
	5069541121	28.2 mm
	5069541123	28.7 mm
	5069541125	29.2 mm
	5069541127	29.7 mm
	5069541129	30.2 mm
	5069541132	30.7 mm
	5069541134	31.2 mm
	5069541136	31.7 mm
	5069541138	32.2 mm
	5069541141	32.7 mm
	5069541143	33.2 mm
	5069541145	33.7 mm
	5069541147	34.2 mm
	5069541149	34.7 mm
	5069541152	35.2 mm
	5069541154	35.7 mm
	5069541156	36.2 mm
	5069541158	36.7 mm
	5069541161	37.2 mm
	5069541163	37.7 mm
	5069541165	38.2 mm
	5069541167	38.7 mm
	5069541169	39.2 mm
	5069541172	39.7 mm
	5069541174	40.2 mm
	5069541176	40.7 mm
	5069541178	41.2 mm
	5069541179	41.5 mm
	5069541181	41.7 mm
	5069541183	42.2 mm
	5069541185	42.7 mm
	5069541187	43.2 mm
	5069541188	43.5 mm
	5069541189	43.7 mm
	5069541192	44.2 mm
	5069541194	44.7 mm
	5069541196	45.2 mm
	5069541198	45.7 mm
	5069541201	46.2 mm
	5069541203	46.7 mm
	5069541205	47.2 mm
	5069541207	47.7 mm
	5069541209	48.2 mm
	5069541212	48.7 mm
	5069541214	49.2 mm
	5069541216	49.7 mm
	5069541218	50.2 mm
	5069541221	50.7 mm

**Vierkantmatrize Nr. 11**

**Square Die No. 11**

**Code 50695 4 2**

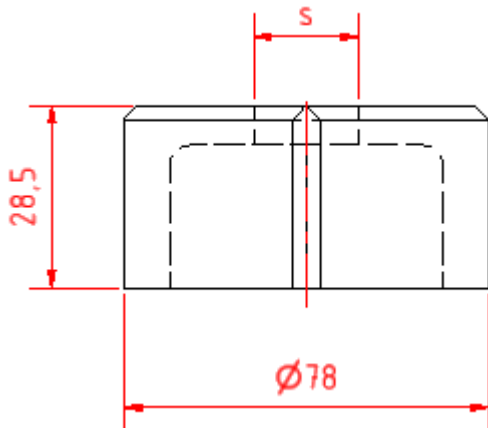
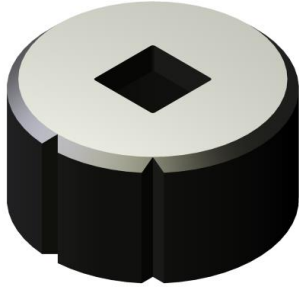

Menge	Artikelnummer	Abmessung
	5069542193	20.2 mm
	5069542195	20.7 mm
	5069542197	21.2 mm
	5069542201	21.7 mm
	5069542203	22.2 mm
	5069542205	22.7 mm
	5069542207	23.2 mm
	5069542211	23.7 mm
	5069542213	24.2 mm
	5069542215	24.7 mm
	5069542217	25.2 mm
	5069542221	25.7 mm
	5069542223	26.2 mm
	5069542225	26.7 mm
	5069542227	27.2 mm
	5069542231	27.7 mm
	5069542233	28.2 mm
	5069542235	28.7 mm
	5069542237	29.2 mm
	5069542241	29.7 mm
	5069542243	30.2 mm
	5069542245	30.7 mm
	5069542247	31.2 mm
	5069542251	31.7 mm
	5069542253	32.2 mm
	5069542255	32.7 mm
	5069542257	33.2 mm
	5069542261	33.7 mm
	5069542263	34.2 mm
	5069542265	34.7 mm
	5069542267	35.2 mm
	5069542268	35.7 mm

**Langlochmatrize Nr. 11**

**Oblong Die No. 11**

**Code 50695 4 3**

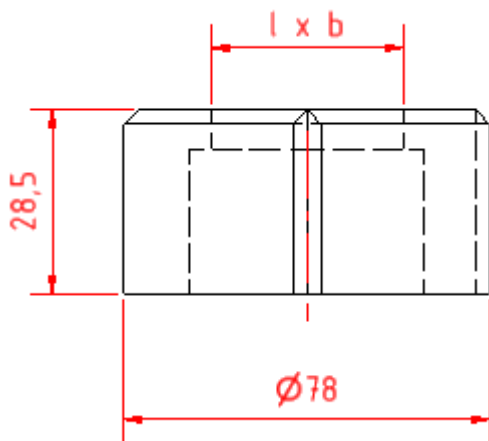
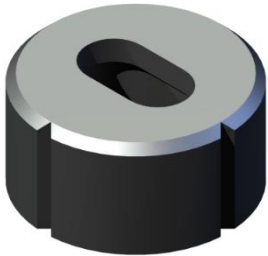

Menge	Artikelnummer	Abmessung
	5069543091	10.2 x 45.2 mm
	5069543093	10.7 x 45.7 mm
	5069543095	10.2 x 50.2 mm
	5069543097	10.7 x 50.7 mm
	5069543102	11.2 x 45.2 mm
	5069543103	11.7 x 45.7 mm
	5069543104	11.2 x 50.2 mm
	5069543105	11.7 x 50.7 mm
	5069543114	12.2 x 45.2 mm
	5069543115	12.7 x 45.7 mm
	5069543116	12.2 x 50.2 mm
	5069543117	12.7 x 50.7 mm
	5069543120	13.2 x 45.2 mm
	5069543122	13.7 x 45.7 mm
	5069543124	13.2 x 50.2 mm
	5069543126	13.7 x 50.7 mm
	5069543208	14.2 x 45.2 mm
	5069543210	14.7 x 45.7 mm
	5069543212	14.2 x 50.2 mm
	5069543214	14.7 x 50.7 mm
	5069543216	16.2 x 45.2 mm
	5069543218	16.7 x 45.7 mm
	5069543220	16.2 x 50.2 mm
	5069543222	16.7 x 50.7 mm
	5069543224	18.2 x 45.2 mm
	5069543226	18.7 x 45.7 mm
	5069543228	18.2 x 50.2 mm
	5069543230	18.7 x 50.7 mm
	5069543232	20.2 x 45.2 mm
	5069543234	20.7 x 45.7 mm
	5069543236	20.2 x 50.2 mm
	5069543238	20.7 x 50.7 mm
	5069543197	22.2 x 45.2 mm
	5069543198	22.7 x 45.7 mm
	5069543201	22.2 x 50.2 mm
	5069543202	22.7 x 50.7 mm

**Rundmatrize Nr. 12**

**Round Die No. 12**

**Code 50695 7 1**

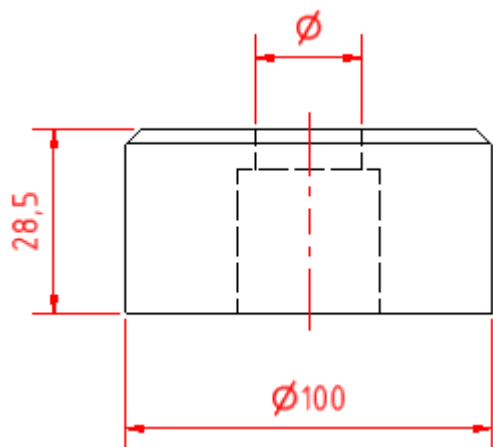
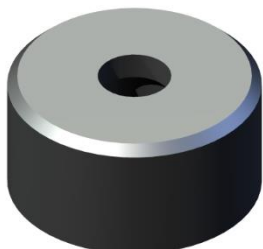

Menge	Artikelnummer	Abmessung
	5069571227	52.2 mm
	5069571229	52.7 mm
	5069571236	54.2 mm
	5069571238	54.7 mm
	5069571245	56.2 mm
	5069571247	56.7 mm
	5069571254	58.2 mm
	5069571256	58.7 mm
	5069571258	59.2 mm
	5069571263	60.2 mm
	5069571265	60.7 mm
	5069571269	61.7 mm
	5069571272	62.2 mm
	5069571274	62.7 mm
	5069571281	64.2 mm
	5069571283	64.7 mm
	5069571289	66.2 mm
	5069571292	66.7 mm
	5069571303	68.2 mm
	5069571305	68.7 mm
	5069571312	70.2 mm
	5069571314	70.7 mm
	5069571321	72.2 mm
	5069571323	72.7 mm
	5069571329	74.2 mm
	5069571332	74.7 mm

**Vierkantmatrize Nr. 12**

**Square Die No. 12**

**Code 50695 7 2**

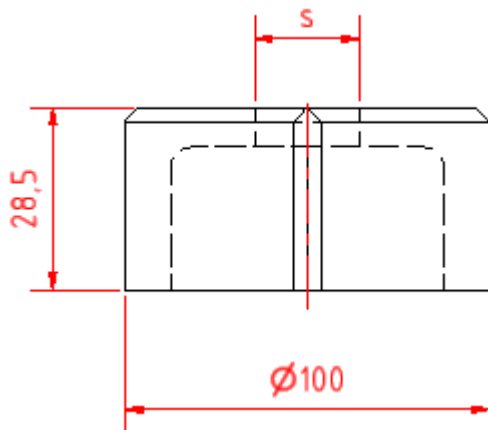
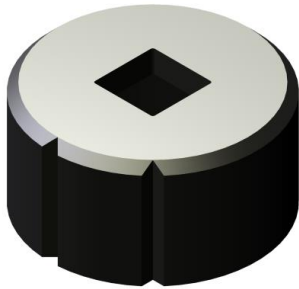

Menge	Artikelnummer	Abmessung
	5069572402	40.2 mm
	5069572407	40.7 mm
	5069572452	45.2 mm
	5069572457	45.7 mm
	5069572502	50.2 mm
	5069572507	50.7 mm

**Langlochmatrize Nr. 12**

**Oblong Die No. 12**

**Code 50695 7 3**

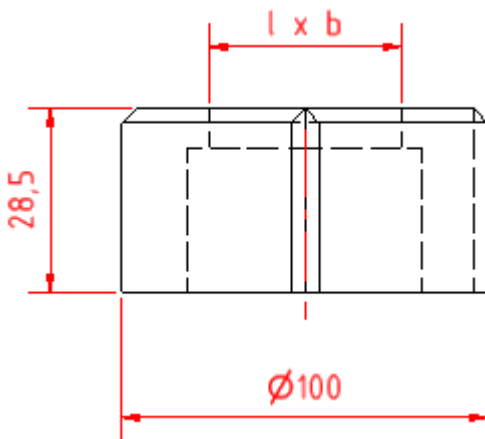
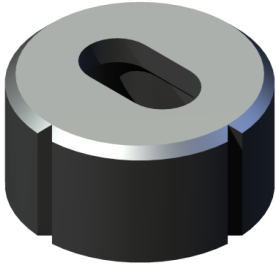

Menge	Artikelnummer	Abmessung
	5069573420	10.2 x 55.2 mm
	5069573422	10.7 x 55.7 mm
	5069573424	10.2 x 75.2 mm
	5069573426	10.7 x 75.7 mm
	5069573428	11.2 x 55.2 mm
	5069573430	11.7 x 55.7 mm
	5069573432	11.2 x 75.2 mm
	5069573433	11.7 x 75.7 mm
	5069573434	12.2 x 55.2 mm
	5069573436	12.7 x 55.7 mm
	5069573438	12.2 x 75.2 mm
	5069573440	12.7 x 75.7 mm
	5069573442	13.2 x 55.2 mm
	5069573444	13.7 x 55.7 mm
	5069573446	13.2 x 75.2 mm
	5069573448	13.7 x 75.7 mm
	5069573450	14.2 x 55.2 mm
	5069573452	14.7 x 55.7 mm
	5069573454	14.2 x 75.2 mm
	5069573456	14.7 x 75.7 mm
	5069573458	16.2 x 55.2 mm
	5069573460	16.7 x 55.7 mm
	5069573462	16.2 x 75.2 mm
	5069573464	16.7 x 75.7 mm
	5069573466	18.2 x 55.2 mm
	5069573468	18.7 x 55.7 mm
	5069573470	18.2 x 75.2 mm
	5069573472	18.7 x 75.7 mm
	5069573474	20.2 x 55.2 mm
	5069573476	20.7 x 55.7 mm
	5069573478	20.2 x 75.2 mm
	5069573480	20.7 x 75.7 mm
	5069573482	22.2 x 55.2 mm
	5069573484	22.7 x 55.7 mm
	5069573486	22.2 x 75.2 mm
	5069573488	22.7 x 75.7 mm

**Rundmatrize Nr. 13**

**Round Die No. 13**

**Code 50695 9 1**

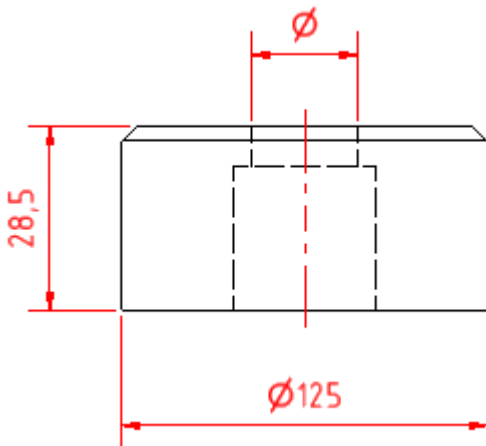
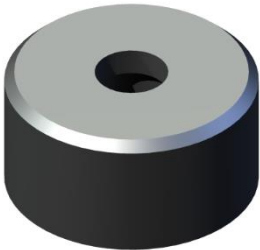

Menge	Artikelnummer	Abmessung
	5069591338	76.2 mm
	5069591341	76.7 mm
	5069591347	78.2 mm
	5069591349	78.7 mm
	5069591356	80.2 mm
	5069591358	80.7 mm
	5069591365	82.2 mm
	5069591367	82.7 mm
	5069591374	84.2 mm
	5069591376	84.7 mm
	5069591383	86.2 mm
	5069591385	86.7 mm
	5069591392	88.2 mm
	5069591394	88.7 mm
	5069591401	90.2 mm
	5069591403	90.7 mm
	5069591409	92.2 mm
	5069591412	92.7 mm
	5069591418	94.2 mm
	5069591421	94.7 mm
	5069591427	96.2 mm
	5069591429	96.7 mm
	5069591436	98.2 mm
	5069591438	98.7 mm
	5069591444	100.2 mm
	5069591445	100.7 mm

**Vierkantmatrize Nr. 13**

**Square Die No. 13**

**Code 50695 9 2**

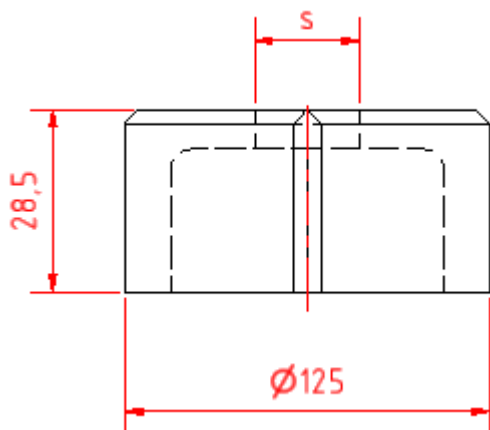
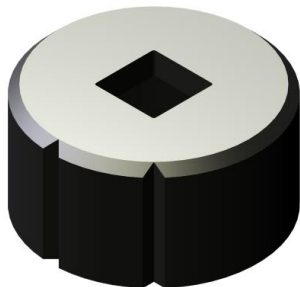

Menge	Artikelnummer	Abmessung
	5069592602	60.2 mm
	5069592607	60.7 mm
	5069592652	65.2 mm
	5069592657	65.7 mm
	5069592702	70.2 mm
	5069592707	70.7 mm

**Langlochmatrize Nr. 13**

**Oblong Die No. 13**

**Code 50695 9 2**

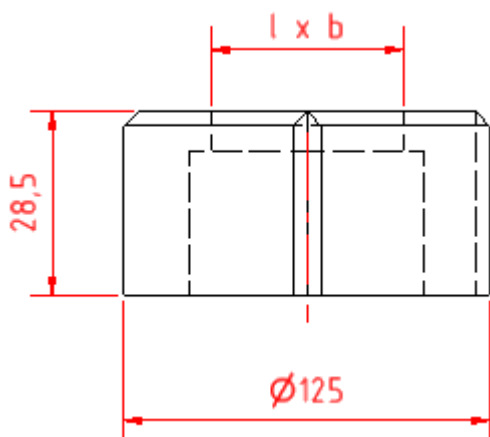
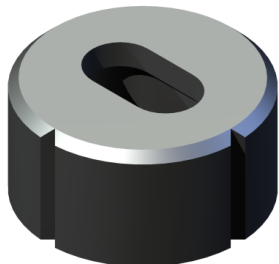

Menge	Artikelnummer	Abmessung
-------	---------------	-----------

\*auf Anfrage / on demand

Werkzeuge zum Stanzen von Löchern für Profilylinder

Tools for punching holes for sectional cylinders

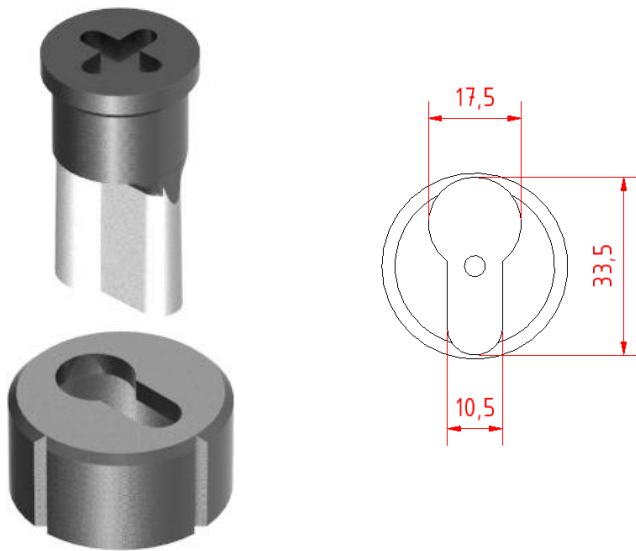

Artikelnummer	Bezeichnung
5059994000	GEKA Profilylinderstempel Nr. 5 *
5059974000	GEKA Profilylinderstempel Nr. 8/31 **
5059984000	GEKA Profilylinderstempel Nr. 8/40
5059904000	GEKA Profilylinderstempel Nr. 10/40
5069564000	GEKA Profilylindermatrize Nr. 5
5069584000	GEKA Profilylindermatrize Nr. 8
5069534000	GEKA Profilylindermatrize Nr. 10

\* nur mit GSA05PZ verwendbar  
 \*\* nur mit GSA8/31PZ verwendbar

Werkzeuge zum Abrunden von Ecken (90°) für Flachmaterial

Tools for rounding off corners (90°) of flats

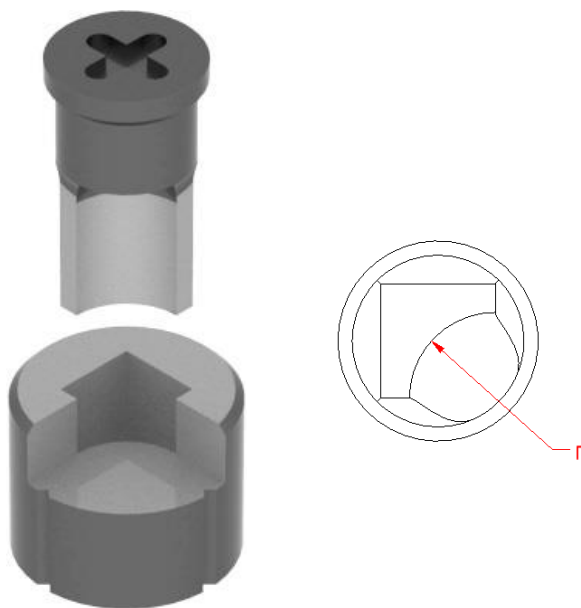

Artikelnummer	Bezeichnung	Radius
5059995005	GEKA Eckenabrundwerkzeug Nr. 5	R - 5 mm
5059995010	GEKA Eckenabrundwerkzeug Nr. 5	R - 10 mm
5059995015	GEKA Eckenabrundwerkzeug Nr. 5	R - 15 mm
5059975008	GEKA Eckenabrundwerkzeug Nr. 8/31	R - 8 mm
5059975012	GEKA Eckenabrundwerkzeug Nr. 8/31	R - 12 mm
5059975015	GEKA Eckenabrundwerkzeug Nr. 8/31	R - 15 mm
5059975020	GEKA Eckenabrundwerkzeug Nr. 8/31	R - 20 mm
5059985020	GEKA Eckenabrundwerkzeug Nr. 8/40	R - 20 mm
5059985026	GEKA Eckenabrundwerkzeug Nr. 8/40	R - 26 mm

Werkzeuge zum Trennen und Abrunden (eine Seite gerade, eine abgerundet)

Tools for cutting and rounding off (one side straight, other side rounded off)

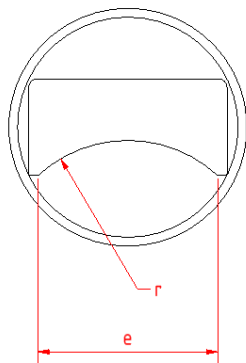

Werkzeugtyp	Flachstahl / Radius	
5	E = 20 x 6 / 15	E = 20 x 6 / 20
8/31	E = 20 x 8 / 15	E = 25 x 8 / 25
8/40	E = 30 x 8 / 20	E = 30 x 10 / 30
10/40	E = 30 x 8 / 20	E = 30 x 10 / 30
11	E = 40 x 10 / 30	E = 40 x 12 / 40
12	E = 50 x 10 / 30	E = 60 x 14 / 45
13	E = 70 x 12 / 40	E = 80 x 14 / 60

Werkzeuge zum gleichzeitigen doppelseitigen Abrunden

Tools for cutting and simultaneously bilateral rounding off

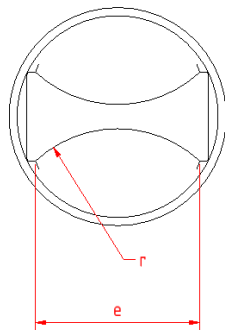

Werkzeugtyp	Flachstahl / Radius	
5	E = 20 x 6 / 15	E = 20 x 6 / 20
8/31	E = 20 x 8 / 15	E = 25 x 8 / 25
8/40	E = 30 x 8 / 20	E = 30 x 10 / 30
10/40	E = 30 x 8 / 20	E = 30 x 10 / 30
11	E = 40 x 10 / 30	E = 40 x 12 / 40
12	E = 50 x 10 / 30	E = 60 x 14 / 45
13	E = 70 x 12 / 40	E = 80 x 14 / 60

**Kapitel 2**

Maschinenersatzteile

Machine spare parts

**2**

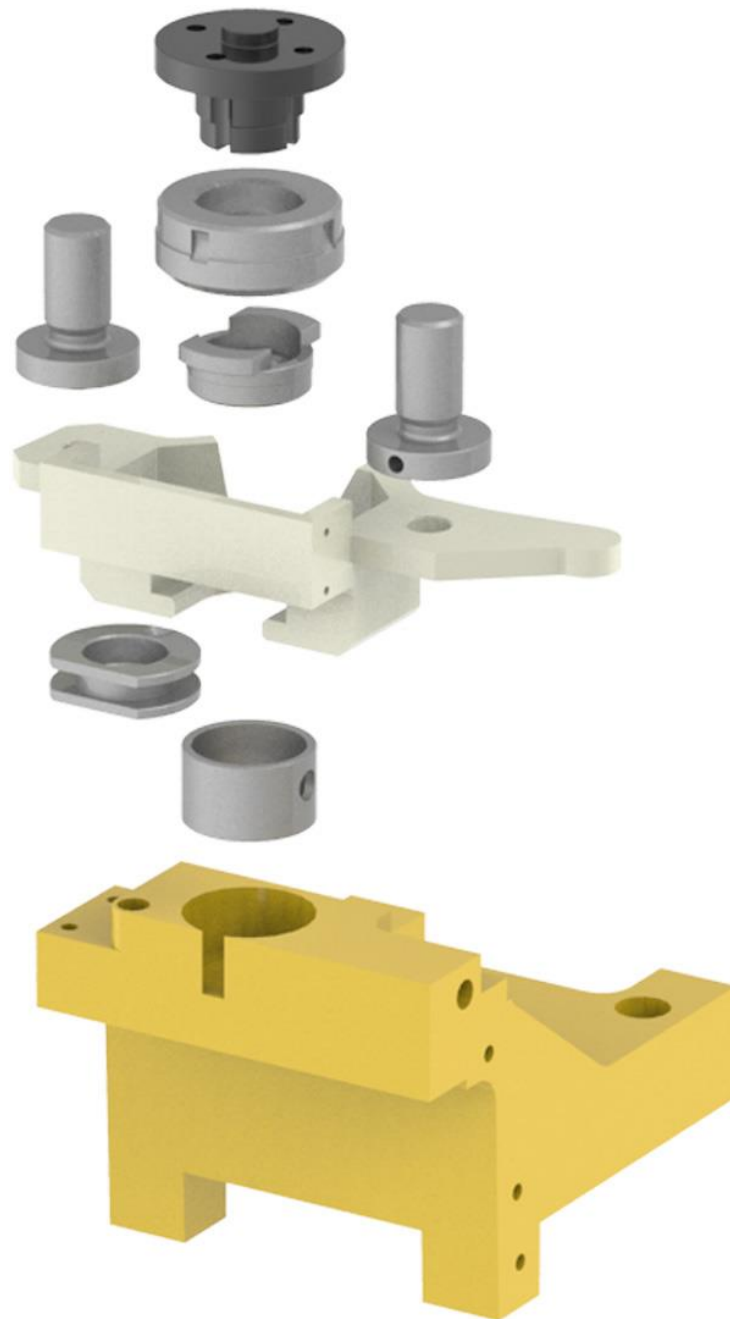

Maschinenersatzteile

Machine spare parts

Abstreifer mit / ohne Einsatz  
Stripper with / without insert

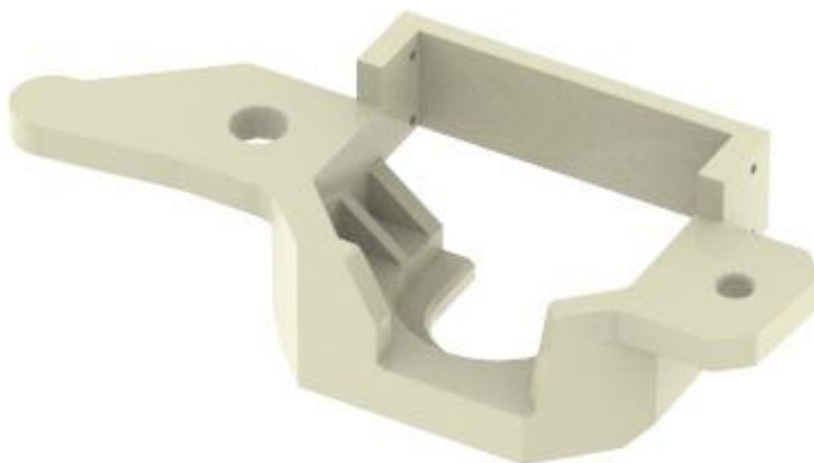

Artikelnummer	Bezeichnung	Modelltyp	Bemerkung
GAS001	GEKA Abstreifer	Multicrop/Minicrop 45 / Bendicrop 50	
GAS002	GEKA Abstreifer	Hydracrop/Puma 50+55+70+80	Komplett
GAS002-E	GEKA Abstreifer	Hydracrop/Puma 50+55+70+80	Einzelteil
GAS002-Ü	GEKA Abstreifer	Hydracrop/Puma 50+55+70+80	Übergroße Stanzeinrichtung
GAS003	GEKA Abstreifer	Hydracrop/Puma 100+110	Komplett
GAS003-E	GEKA Abstreifer	Hydracrop/Puma 100+110	Einzelteil
GAS003-Ü	GEKA Abstreifer	Hydracrop/Puma 100+110	Übergroße Stanzeinrichtung
GAS004	GEKA Abstreifer	PP 50	

Einsatz für kleine Löcher  
Insert for small holes



Artikelnummer	Bezeichnung	Modelltyp
GAE170	GEKA Abstreifereinsatz f. Normalstanzeinrichtung Dm 17.0mm	Hydracrop / Puma 50+55+70+80+100+110

Maschinenersatzteile

Machine spare parts

Stempelhalter  
Punch holder



Artikelnummer	Modelltyp
GSSH001	Microcrop 36
GSSH002	Minicrop / Multicrop 45
GSSH003	Hydracrop / Puma / PP 50 + 70
GSSH004	Hydracrop / Puma 55 + 80
GSSH005	Hydracrop / Puma 100
GSSH006	Bendicrop 50
GSSH008	Hydracrop / Puma 110

Stempelmutter  
clamping nut

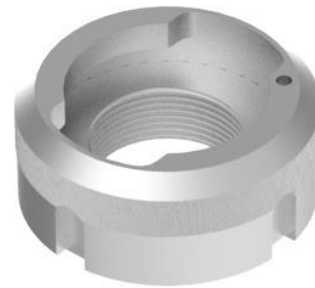

Artikelnummer	Bezeichnung
GSM13	GEKA Stempelmutter SV100 Nr. 13
GSM40x2	GEKA Stempelmutter M40x2
GSM48x2	GEKA Stempelmutter M48x2

Stempeladapter  
Punch adapter

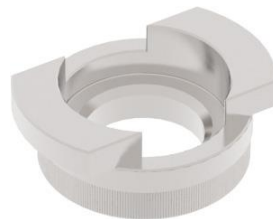

Artikelnummer	Bezeichnung	Bemerkung / für Stempelschaftdurchmesser
GSA05	GEKA Stempeladapter Nr. 05	Ø 27
GSA05-8/31	GEKA Stempeladapter Nr. 05 - Nr. 8/31 – Bendicrop 50	Ø 31
GSA05-PFP04-B	GEKA Stempeladapter Nr. 05 - PFP Nr. 04-B	Ø 30
GSA05PZ	GEKA Stempeladapter Nr. 05 - Profilzylinder	Ø 27 mit Aussparung für Profilzylinder
GSA13-11	GEKA Stempeladapter Nr. 13 - Nr. 11	Ø 50
GSA13-12	GEKA Stempeladapter Nr. 13 - Nr. 12	Ø 75
GSA13-5/27	GEKA Stempeladapter Nr. 13 - Nr. 5/27	Ø 27
GSA13-8/31	GEKA Stempeladapter Nr. 13 - Nr. 8/31	Ø 31
GSA13-8/40	GEKA Stempeladapter Nr. 13 - Nr. 8/40	Ø 40
GSA8/31	GEKA Stempeladapter Nr. 8/31	Ø 31
GSA8/31-05	GEKA Stempeladapter Nr. 8/31 - Nr. 5/27	Ø 27
GSA8/31-ALPS	GEKA Stempeladapter Nr. 8/31 - ALPS150	Ø 31
GSA8/31PZ	GEKA Stempeladapter Nr. 8/31 - Profilzylinder	Ø 31 mit Aussparung für Profilzylinder
GSA8/40	GEKA Stempeladapter Nr. 8/40	Ø 40
GSA8/40-12N	GEKA Stempeladapter Nr. 8/40 - 12N	Ø 12

Maschinenersatzteile

Machine spare parts

Rändeleinstellschraube für Abstreifer  
Adjustable screw for stripper



Artikelnummer	Bezeichnung	Maschinentyp	Bemerkung
GRS001-1	GEKA Rändeleinstellschraube für Abstreifer	Minicrop / Multicrop 45 / Microcrop 36 / PP 50	mit Zapfen
GRS001-2	GEKA Rändeleinstellschraube für Abstreifer	Minicrop / Multicrop 45 / Microcrop 36 / PP 50	mit Gewinde
GRS001-3	GEKA Rändeleinstellschraube für Abstreifer	Minicrop / Multicrop 45 / Microcrop 36 / PP 50	mit Schraube + Feder
GRS002-1	GEKA Rändeleinstellschraube für Abstreifer	Hydracrop / Puma 50 + 55 + 70 + 80	mit Zapfen
GRS002-2	GEKA Rändeleinstellschraube für Abstreifer	Hydracrop / Puma 50 + 55 + 70 + 80	mit Gewinde
GRS002-3	GEKA Rändeleinstellschraube für Abstreifer	Hydracrop / Puma 50 + 55 + 70 + 80	mit Schraube + Feder
GRS003-1	GEKA Rändeleinstellschraube für Abstreifer	Hydracrop / Puma 100 + 110	mit Zapfen
GRS003-2	GEKA Rändeleinstellschraube für Abstreifer	Hydracrop / Puma 100 + 110	mit Gewinde
GRS003-3	GEKA Rändeleinstellschraube für Abstreifer	Hydracrop / Puma 100 + 110	mit Schraube + Feder

Matrizenreduzierung  
Die reducer



Artikelnummer	Bezeichnung	Bemerkung / von Durchmesser auf Durchmesser
GMR0805	GEKA Matrizenreduzierung Nr. 08 - Nr. 05	Ø 60 – Ø 50.8 mm
GMR10-05	GEKA Matrizenreduzierung Nr. 10 - Nr. 05	Ø 73 – Ø 50.8 mm
GMR10-08	GEKA Matrizenreduzierung Nr. 10 - Nr. 08	Ø 73 – Ø 60 mm
GMR13	GEKA Matrizenreduzierung Nr. 13 - Auflage	Ø 125
GMR1305	GEKA Matrizenreduzierung Nr. 13 - Nr. 05	Ø 125 – Ø 50.8 mm
GMR1308	GEKA Matrizenreduzierung Nr. 13 - Nr. 08	Ø 125 – Ø 60 mm
GMR1311	GEKA Matrizenreduzierung Nr. 13 - Nr. 11	Ø 125 – Ø 78 mm

GMR1312	GEKA Matrizenreduzierung Nr. 13 - Nr. 12	Ø 125 – Ø 100 mm
---------	--	------------------

**Maschinenersatzteile**

**Machine spare parts**

Flachstahlmesser  
Flat shear blades

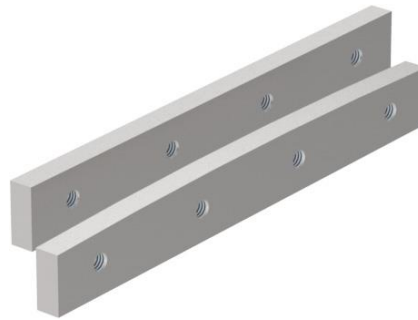

Artikelnummer	Bezeichnung	Bemerkung
GFM001	GEKA Flachstahlmesser	Microcrop 36
GFM001-1	GEKA Flachstahlobermesser	Microcrop 36
GFM001-2	GEKA Flachstahluntermesser	Microcrop 36
GFM002	GEKA Flachstahlmesser	Minicrop 45 / Multicrop 45
GFM002-1	GEKA Flachstahlobermesser	Minicrop 45 / Mutlicrop 45
GFM002-2	GEKA Flachstahluntermesser	Minicrop 45 / Mutlicrop 45
GFM003	GEKA Flachstahlmesser	Bendicrop 50
GFM003-1	GEKA Flachstahlobermesser	Bendicrop 50
GFM003-2	GEKA Flachstahluntermesser	Bendicrop 50
GFM004	GEKA Flachstahlmesser	Hydracrop 50 / 55
GFM004-1	GEKA Flachstahlobermesser	Hydracrop 50 / 55
GFM004-2	GEKA Flachstahluntermesser	Hydracrop 50 / 55
GFM005	GEKA Flachstahlmesser	Hydracrop 70 / 80
GFM005-1	GEKA Flachstahlobermesser	Hydracrop 70 / 80
GFM005-2	GEKA Flachstahluntermesser	Hydracrop 70 / 80
GFM006	GEKA Flachstahlmesser	Hydracrop 100 / 110
GFM006-1	GEKA Flachstahlobermesser	Hydracrop 100 / 110
GFM006-2	GEKA Flachstahluntermesser	Hydracrop 100 / 110

verstellbare Klemmhebel  
adjustable handle



Artikelnummer	Bezeichnung
GKS12030	GEKA Klemmschraube M12 x 30
GKS12040	GEKA Klemmschraube M12 x 40
GKS16030	GEKA Klemmschraube M16 x 30

**GEKA**

**KEWEMA**

Werkzeuge- und Maschinen-Vertriebs-GmbH

Telefon: +49 (0) 7854 – 8 77 38 20  
+49 (0) 7854 – 8 77 38 21  
Telefax: +49 (0) 7854 – 8 77 38 49

e-mail: [info@kewema.de](mailto:info@kewema.de)  
Internet: [www.kewema.de](http://www.kewema.de)