

Air Fröhlich

Glass Tube heat exchangers

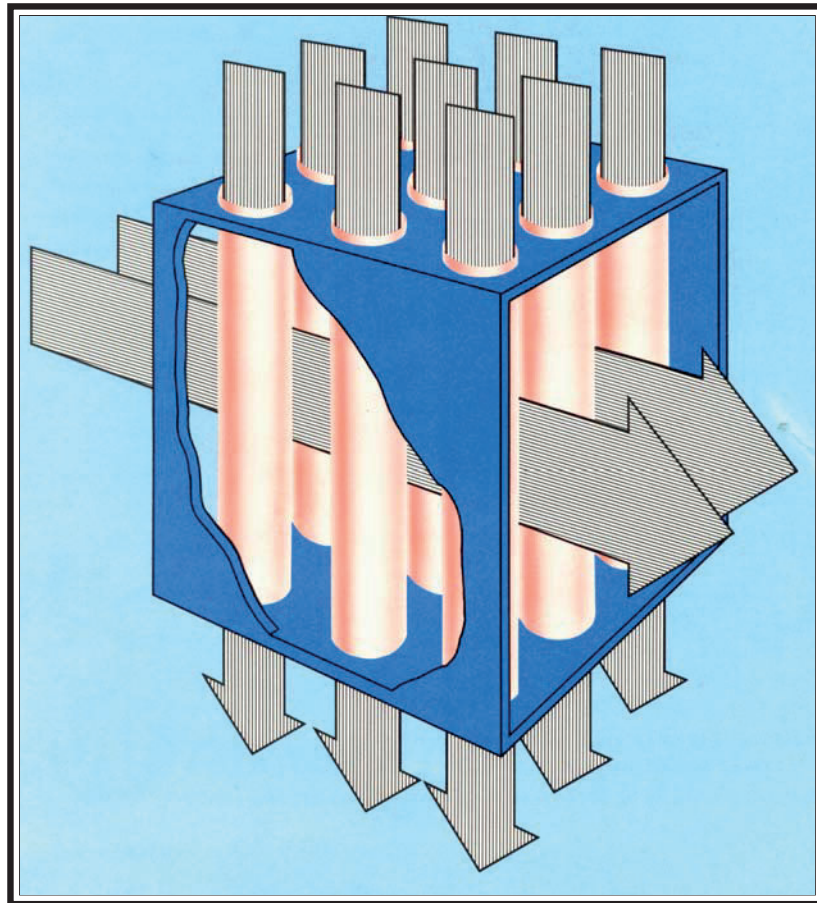
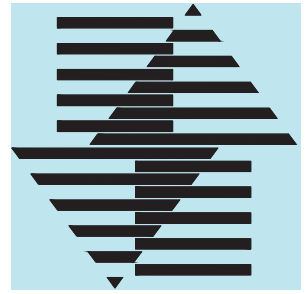

Industrial processes, dirty and corrosive
extract air, swimming halls, flue gas etc.

Sales:
Taniplan Oy
Kylätie 18 B 20
00320 Helsinki
Mob. 0500 426631
Email info@taniplan.fi
<http://www.taniplan.fi>



Air Fröhlich glass-tube heat exchangers

GRS-K-133 heat exchanger

Common properties

Air Fröhlich- glass tube heat exchangers are especially designed for industrial processes, hospitals, commercial kitchens, swimming halls, corrosive exhausts, animal sheds, galvanic and ceramical industry etc.

Reference code

Example: **GRS - K - 133 - 090 - B**

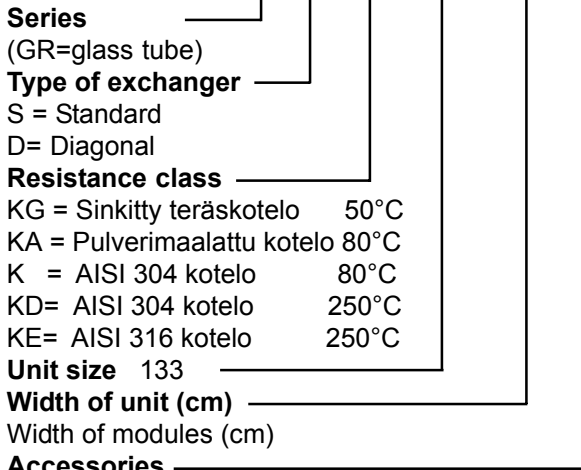

Accessories

B = By-pass
BS= By-pass + by-pass/sector damper

Operating range

Max.temperature	50/80/250°C
Max.pressure drop inside of tube	500 Pa
Max.pressure drop outside of tube	250 Pa
Max.differential pressure inside/ouside	2500 Pa
Efficiency factor	1,8
Frost limit factor	5

Module heat exchanger modell GRS-K-133

GRS-K-133 Heat Exchanger is manufactured of standard glass tube modules type 1500-46-11 by assembling them side by side.

Dimensions L/B/H of module are 1560/300/1090 mm and weight is 95 kg.

By choosing a proper number of modules wanted air flow and pressure drop can be chosen. Outermost modules can be equipped with side panels.

Accessories

By-pass	Built in the case at outside air side. Width is depending on the width of the heat exchanger.
Sector damper	Mounted at outside air inlet. Dimensions according to dimensions of the heat exchanger (Look at page 4).
Counterflanges	Delivery if separately ordered.

Pressure drop and air flow factor

Diagram below gives pressure drops for cold (in tube) air flow and warm (outside of tube) air flow and air flow factor inside of tube. Values are valid at 0°C air temperature. Pressure drops for other temperatures: formulas are found on page 3.

Frost limit temperature

By using frost limit factor 5,0 and air flow factor from diagram below the frost limit temperature can be determined by diagram on page 9. More about freezing protection systems on pages 4 and 8.

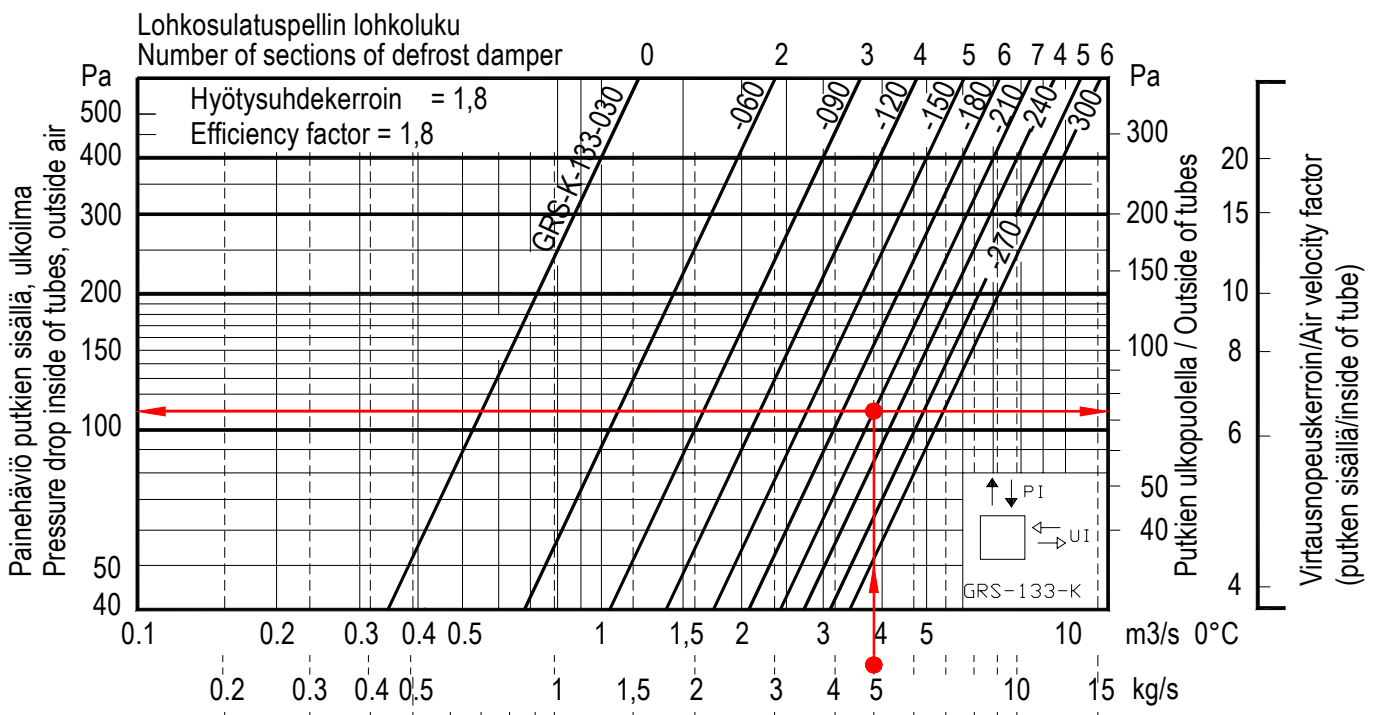



Air Fröhlich glass-tube heat exchangers

GRS-K-133 heat exchanger

Diagram (page 2):

Outside air pressure drop is found at left and exhaust air pressure drop at right edge of diagram. Values are valid at air temperature 0°C. Outside air pressure drop is 1,5 x exhaust air pressure drop. Air density at 0°C and water contents 3,5 g H₂O/kg dry air is 1.27 kg/m³.

Pressure drop at other temperatures at constant mass flow of air can be determined by equations below:

Pressure drop from diagram: Δp_0

Pressure drop at altered density: $\Delta p_2 = \frac{\rho_0}{\rho_2} \Delta p_0$

Pressure drop at altered temperature: $\Delta p_2 = \frac{T_2}{273} \Delta p_0$

Density of air (wet air): $\rho_2 = 2167 \cdot \frac{(1 + x_2)}{T_2 \cdot (0,622 + x_2)}$

[T] = K , absolute temperature, [x] = kg/kg, water contents of air and [ρ] kg/m³, density of air.

Example: Heat Exchanger GRS-KE-133-210, exhaust air is 6 m³/s at mean temperature 140°C and water contents 0.020 kg/kg wet air. Determine exhaust air pressure drop.

Density of air is $2167 \cdot (1 + 0.02) / ((273 + 140) \cdot (0.622 + 0.02)) = 0.834 \text{ kg/m}^3$. Mass flow of air is $0.834 \cdot 6 = 5.0 \text{ kg/s}$. Air flow 5 kg/s in diagram gives pressure drop 74 Pa. At 413 K (140°C): $\Delta p = 413/273 \cdot 74 = 113 \text{ Pa}$. The same result by using densities: $1.27/0.834 \cdot 74 = 113 \text{ Pa}$.

Note! Calculations shall be done by using average temperature inside of the heat exchanger.

Frost limit

If frost shall be eliminated there are two ways it can be reliably done: preheating of outside air or using so called sector defrosting system.

Heating of outside air: Outside air is heated by means of electric heating coil or liquid (water-glycol) heating coil from outside temperature to defrost limit temperature (diagram).

Sector defrost system: The heat exchanger is on o.a. side vertically divided in 3 - 6 sections which can be separately closed by a sector damper. Only one section at a time is closed. All sectors are defrosted in turn. Defrosting time (that is time sector damper is closed) is 10...15 minutes depending on humidity of extract air.

Defrosting process is working continuously allways when outside air temperature is below frost limit temperature. Sector defrosting can be used to -45°C outside air temperature. Total efficiency of the heat exchanger is lowered only in the proportion of number of working sectors to total number (n) of sectors:

$$\eta_{red} = \frac{(n - 1)}{n} \cdot \eta$$

Principle of sector

defrosting:

Second damper from left is closed, that is in defrosting position.

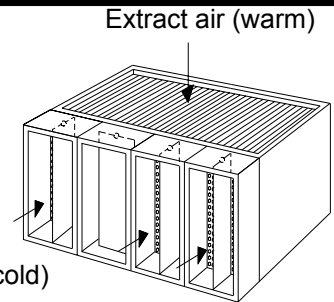

Determination of efficiency

The definition of the efficiency of recuperative heat exchangers as used in this context is:

Efficiency = Outside air heating in the heat exchanger with regard to the total available temperature difference.

$$\eta = \frac{t_3 - t_2}{t_1 - t_2}$$

t₁ = Extract air temperature entering heat exchanger

t₂ = Outside air temperature entering heat exchanger

t₃ = Outside air temperature leaving heat exchanger

The procedure determining efficiency by means of factors and efficiency diagram is equal to A, D and E heat exchangers on page 8.

GRS-K-133 dimensions and weights

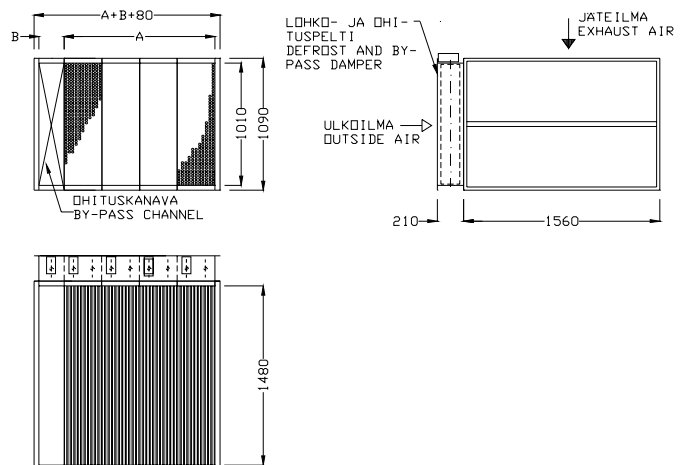

Type	Number of modules	Dimensions (mm)		Weight (kg)	
		A	B	No bypass	Bypass
GRS-K-133					
-030	1	300	50	159	184
-060	2	600	100	254	284
-090	3	900	150	349	379
-120	4	1200	200	444	479
-150	5	1500	300	539	579
-180	6	1800	300	634	674
-210	7	2100	450	729	774
-240	8	2400	450	824	869
-270	9	2700	600	919	969
-300	10	3000	600	1014	1064



Air Fröhlich glass-tube heat exchanger type A, D and E

General data, resistance classes

General data

Glass-tube heat exchangers operate on the principle of heat transfer through a dividing wall from a hot gaseous medium (air) to a cold gaseous medium (air). They are especially suitable for flue gas heat recovery installations, industrial processes using hot air, industrial ventilation and larger H + V installations. The following charts and tables enable the appropriate type of heat exchanger to be selected and its efficiency to be determined.

Reference code: GRS - A - 112 - 121

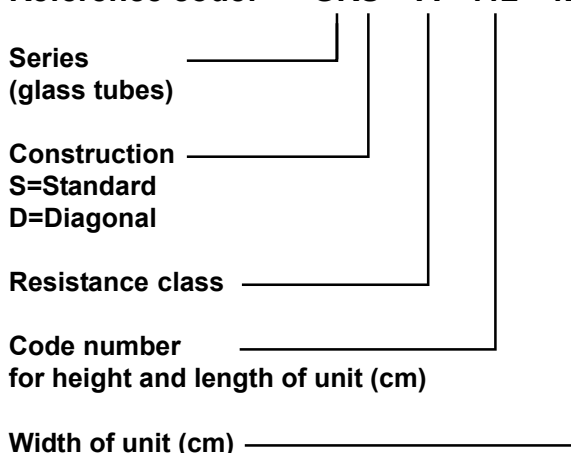

Resistance classes

The resistance classes depend upon the materials used in relation to the temperature limits and the chemicals resistance. The types of recuperator referred to in this leaflet are supplied in the resistance classes A, D, E.

Air flow

The two air masses can either flow around or through the tubes. The pressure drop is almost equal for the same amount of air and the same temperature. It is recommended that the very dirty exhaust air be passed around the tubes. This applies also in air conditioning applications. In the case of resistance class S only the area around the tubes is highly anticorrosive.

Frost limit

When used air for air conditioning applications the surface temperature of the tubes on the exhaust air side may fall below the freezing point.

When the exhaust air circulates around the tubes, no precautions against frost formation needs to be taken. In fact the unit will partially ice up, but this is not dangerous. It should however be noted that in this case the pressure drop increases and the efficiency drops. The number of days in a year on which there is any risk of frost information is very small, so the effect is of no importance. If frost shall be eliminated there are two ways it can be reliable done: preheating of outside air or using so called sector defrosting system.

Heating of outside air: Outside air is heated by means of electric heating coil or liquid (water-glycol) heating coil from outside temperature to defrost limit temperature (diagram).

Sector defrost system: The heat exchanger is on o.a. side vertically divided in 3 - 6 sections which can be separately closed by a sector damper. Only one section at a time is closed. All sectors are defrosted in turn. Defrosting time (that is time sector damper is closed) is 10...15 minutes depending on humidity of extract air.

Defrosting process is working continuously allways when outside air temperature is below frost limit temperature.

Sector defrosting can be used to -45°C outside air temperature. Total efficiency of the heat exchanger is lowered only in the proportion of number of working sectors to total number (n) of sectors:

$$\eta_{red} = \frac{(n - 1)}{n} \cdot \eta$$

Principle of sector defrosting:
Second damper from left is closed, that is in defrosting position.

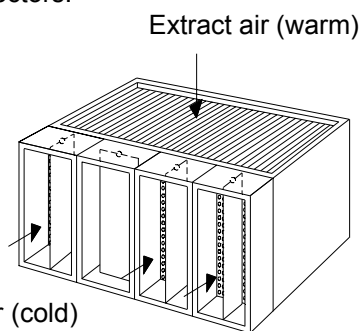

Criteria	Resistance Class A	Resistance Class D	Resistance Class E
Temperature range	... 80 °C	... 150 °C	... 250 °C
Max. Operating Pressure	5000 Pa	10,000 Pa	10,000 Pa
Max. diff. pressure	500 Pa	500 Pa	500 Pa
Casing type	Mild Steel, powder coated	Stainless Steel V2A, DIN 1.4301 (AISI 304)	Stainless Steel V4A, DIN 1.4401 (AISI 316) Special materials on request.
Tube Sealing	Sealing Compound PU-Base	Sealing Compound Silicon	Sealing Compound Silicon
Typical Applications	- Air Conditioning (kitchens, indoor swimming-pools) - Industrial ventilation - Laboratories - Hospitals	Industrial Drying Plants	Flue gases from - Gas fired boilers - Drying plants



Air Fröhlich glass-tube heat exchanger type A, D and E

Selection of heat exchanger, actual pressure drop

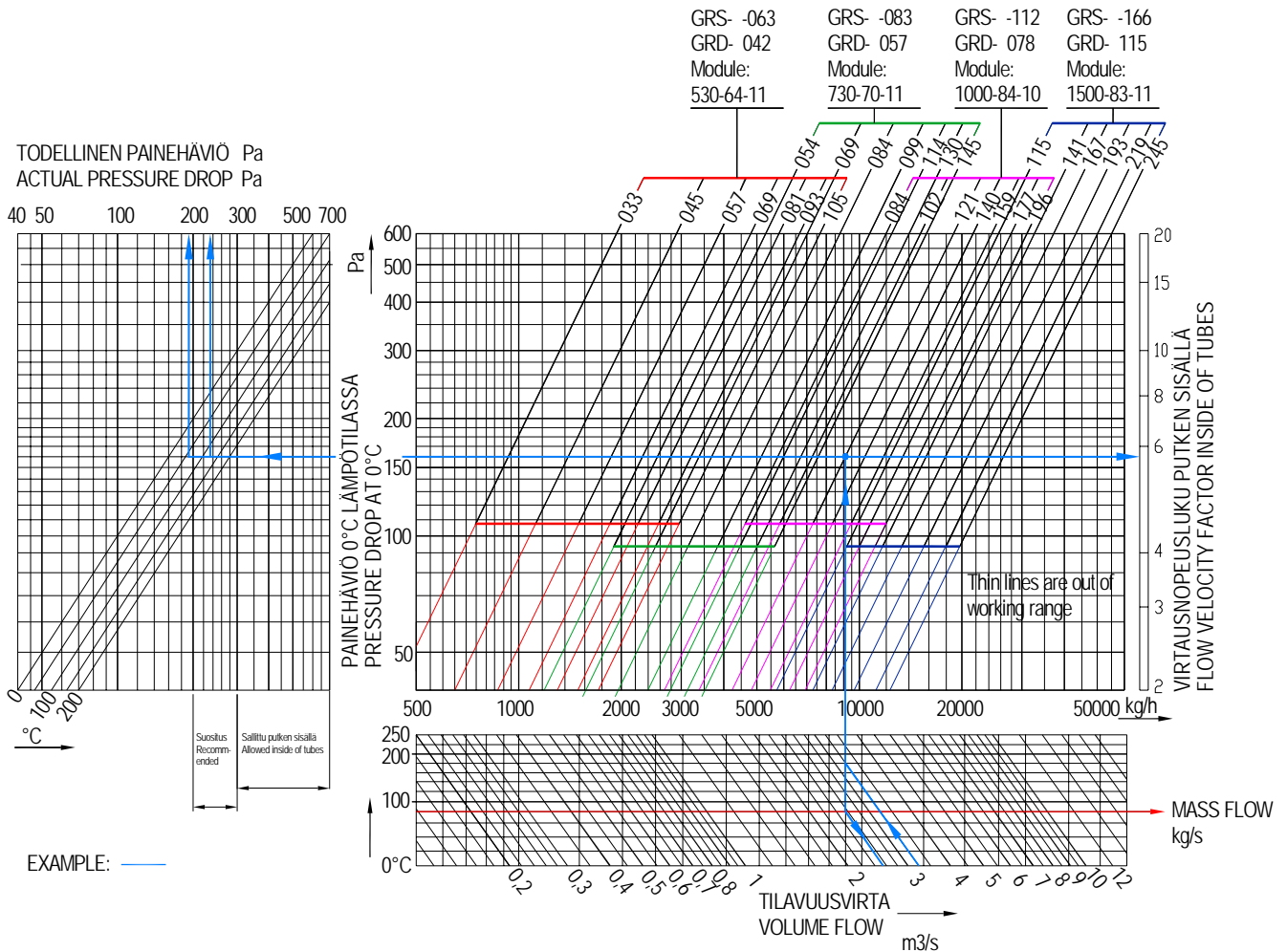

Medium air temperature in heat exchanger can be calculated according to formulas below:

Glass tube heat exchangers are manufactured by using standard modules.

$$t_{m\ cold} = 0,7 \cdot t_{cold} + 0,3 \cdot t_{warm}$$

$$t_{m\ warm} = 0,7 \cdot t_{warm} + 0,3 \cdot t_{cold}$$

Example:

Exhaust air flow: 3.2 m³/s at 180°C

Outside air flow: equal mass flow at 0°C

From diagram:

Mass flow: approx. 2.5 kg/s = 9000 kg/h -> Selected: GRS-112-121

Pressure drop: Extract air temperature $t_{m\ warm} = 126^\circ\text{C}$, $D_p = 230$ Pa; outside air temperature $t_{m\ cold} = 54^\circ\text{C}$, $D_p = 195$ Pa.

Flow velocity factor is approximately 6.

Glass tube modules

Glass tube heat exchangers are manufactured using standard modules (table below):

Heat exchanger type	Module	A (mm)	B (mm)	C (mm)	V (m ³ /s)	G (kg)	Effic. factor	Frost lim.factor
GRS-063/GRD-042	530-64-11	538	120	530	0,145	11	2,2	3,0
GRS-083/GRD-057	730-70-11	738	151	730	0,260	20	2,2	3,0
GRS-112/GRD-078	1000-84-10	1018	188	1000	0,476	44	2,2	2
GRS-166/GRD-115	1500-83-11	1528	259	1490	0,845	94	2,3	2



Air Fröhlich glass-tube heat exchanger type A, D and E Dimensions

Standard type GRS

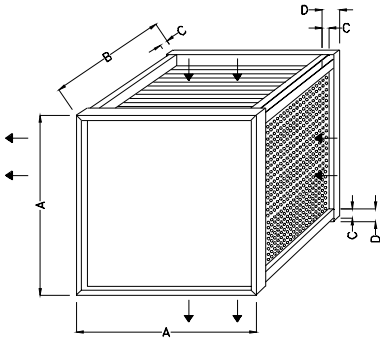

Types (supplied in resistance classes A, D and E)	Number of modules	Dimensions in mm				Weight in kg	Factors for		
		A	B	C	D		Frost limit	Efficiency	
GRS-063-033	2	630	322	40	60	30	3	2,2	
	-045	3	630	442	40	60			40
	-057	4	630	562	40	60			50
	-069	5	630	685	40	60			60
	-081	6	630	805	40	60			70
	-093	7	630	925	40	60			80
GRS-083-054	3	830	535	40	60	67	3	2,2	
	-069	4	830	685	40	60			84
	-084	5	830	838	40	60			101
	-099	6	830	990	40	60			118
	-114	7	830	1140	40	60			135
	-130	8	830	1295	40	60			153
GRS-112-084	4	1120	832	40	60	195	2	2,2	
	-102	5	1120	1022	40	60			235
	-121	6	1120	1210	40	60			275
	-140	7	1120	1395	40	60			315
	-159	8	1120	1585	40	60			356
	-177	9	1120	1770	40	60			396
GRS-166-115	4	1660	1150	55	80	428	2	2,3	
	-141	5	1660	1410	55	80			515
	-167	6	1660	1670	55	80			601
	-193	7	1660	1930	55	80			688
	-219	8	1660	2190	55	80			775
	-245	9	1660	2450	55	80			861

* Only for use in the horizontal position. Units are transported in the position of the installation.

Diagonal type GRD

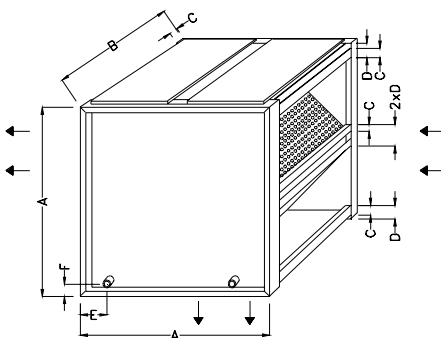

Types (supplied in resistance classes A, D and E)	Number of modules	Dimensions in mm						Weight in kg	Factors for		
		A	B	C	D	E	F		Frost limit	Efficiency	
GRD-042-033	2	840	322	40	60	75	35	42	3	2,2	
	-045	3	840	442	40	60	75	35			54
	-057	4	840	562	40	60	75	35			66
	-069	5	840	685	40	60	75	35			78
	-081	6	840	805	40	60	75	35			90
	-093	7	840	925	40	60	75	35			102
GRD-057-054	3	1130	535	40	60	75	35	106	3	2,2	
	-069	4	1130	685	40	60	75	35			128
	-084	5	1130	838	40	60	75	35			149
	-099	6	1130	990	40	60	75	35			171
	-114	7	1130	1140	40	60	75	35			193
	-130	8	1130	1295	40	60	75	35			215
GRD-078-084	4	1550	832	40	60	75	35	237	2	2,2	
	-102	5	1550	1022	40	60	75	35			275
	-121	6	1550	1210	40	60	75	35			324
	-140	7	1550	1395	40	60	75	35			374
	-159	8	1550	1585	40	60	75	35			423
	-177	9	1550	1770	40	60	75	35			472
GRD-115-115	4	2300	1150	55	80	90	35	570	2	2,3	
	-141	5	2300	1410	55	80	90	35			634
	-167	6	2300	1670	55	80	90	35			741
	-193	7	2300	1930	55	80	90	35			847
	-219	8	2300	2190	55	80	90	35			954
	-245	9	2300	2450	55	80	90	35			1061

We reserve the right to alter dimensions and weights



Air Fröhlich glass-tube heat exchanger type A, D and E Installation, accessories

Position of installation

Standard construction GRS

Normal position

The tubes are in horizontal position.

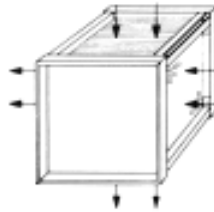

Vertical position

The tubes are in the vertical position.

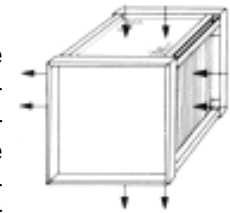

Horizontal position

(both flows pass horizontally through the heat exchangers) If required, a horizontal installation is also possible. Condensate drainage has to be provided on the exhaust air outlet side. The flow of condensate towards the exhaust air inlet side is prevented by the special construction of the heat exchanger. To improve the drainage of condensate or cleaning water, the heat exchanger may be installed slightly inclined. Whether or not a droplet separator needs to be fitted to the fresh air outlet should also be considered.

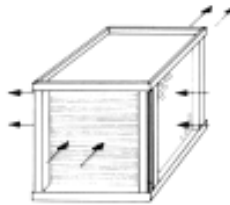

Diagonal construction GRD

Diagonal type are fitted with the same heat exchanger units, and therefore have the same operating characteristics as the corresponding standard types (see sketches showing overall dimensions).

When installing these types it is important to check that the exhaust air is correctly led through the unit (usually around the tubes) and that the drains are connected up accordingly. (If the unit needs to be cleaned also on the fresh air side, both drains have to be connected.) The need for a droplet separator should be considered for each individual case. (On request this will be supplied by AIR FRÖHLICH installed within the casing, at extra cost.)

Please specify the position of installation on the order since the larger types are usually transported in the position of installation. If this is not specified we supply the units in the normal position.

Accessories

Bypass

Glass tube heat exchangers (except type GRS-267) can be fitted if required with a built-in Bypass for output control at an additional cost.

Unit sizes (with built-in bypass)

The bypass width is a fix measurement and can not be changed. - The letter "B" has to be added to the type reference code. Example: GRD-A-057-054-B.

Type	Bypass width (mm)		Total width (mm)	
	GRS	GRD	GRS	GRD
GRS-063 -033 and -045 GRD-042 -057	50	100	372	422
	50	100	492	542
	100	130	662	692
	100	155	785	840
	130	180	935	985
	130	220	1055	1145
GRS-083 -054 and -069 GRD-057 -084	155	250	1200	1295
	100	130	635	665
	100	155	785	840
	130	180	968	1080
	155	220	1145	1210
	155	250	1295	1390
GRS-112 -84 and -102 GRD-078 -121	180	320	1475	1615
	220	320	1665	1765
	100	180	932	1012
	130	220	1152	1240
	155	250	1365	1460
	180	250	1575	1645
GRS-166 -115 and -141 GRD-115 -167	220	320	1805	1905
	250	400	2020	2170
	250	400	2210	2360
	155	220	1305	1370
	180	250	1590	1660
	220	320	1890	1990
GRD-115 -193 -219 -245	250	400	2180	2330
	320	-	2510	-
	320	-	2770	-

Dampers

On request and at an extra cost Bypassunits can be supplied with integral counter-acting dampers. Damper drive and controls however have to be supplied by others.

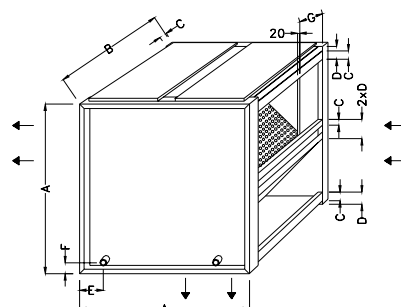
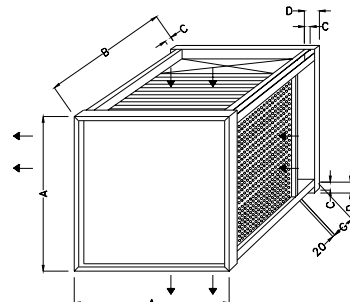



Air Fröhlich glass-tube heat exchanger type A, D and E

Efficiency and frost limit

Additional items available from Air Fröhlich

In addition to the types of heat exchangers described in this brochure Air Fröhlich also supplies special Glass Tube Units such as:

- Block type units for large air volumes GRS-D/H
- V-shaped units GRV
- Units for temperatures up to 500°C GRS-T
- "Oeko"-series GRS-K
- Modular type for heavy dust loads GRM
- Counter-crossflow units GR2
- For integral installation into AC-units GR01
- Units for use in animal stabling GRS-Ds

Heat exchangers are also available in synthetic materials and in stainless steel and for direct heating of water by waste air. Technical data and other information on request.

Air flow factor

Air flow rates through the heat exchanger govern the efficiency and frost limit of the unit since they are relevant to the heat transfer factor. Each flow rate can be assigned to a factor which represents a measurement of the effective heat exchanger efficiency. This air flow factor can be taken from the pressure drop diagram.

Efficiencies

The definition of the efficiency of recuperative heat exchangers as used in this context is:

Efficiency = Outside air heating in the heat exchanger with regard to the total available temperature difference.

$$\eta = \frac{t_3 - t_2}{t_1 - t_2}$$

- t_1 = Extract air temperature entering heat exchanger
- t_2 = Outside air temperature entering heat exchanger
- t_3 = Outside air temperature leaving heat exchanger

The efficiency which will be obtained without condensation is called "dry efficiency".

This dry efficiency is, at given mass-flows, a typical heat exchanger related factor and is reflected in the efficiency factor. This factor can be read from the data sheets for the various types of heat exchanger.

The effective efficiency takes into account stated air flow rates, air mass relationships and the amount of condensation. It can be determined for each operating condition by reference to the efficiency diagram.

Determination of efficiency

- a) Choose the appropriate heat exchanger type from the resistance class specification and select relevant **efficiency factor** from data sheet.
- b) Starting from the temperature difference value on the bottom left of the efficiency diagram, follow upwards to the curve for the corresponding relative humidity of the exhaust air.
- c) Then draw a line horizontally to the right to the intersection of the relevant **efficiency factor** line.
- d) Draw the next line vertically upwards to the intersection with the relevant **air flow factor** line (previously obtained from the pressure drop diagram).
- e) Draw a horizontal line to the left to the intersection with the appropriate value of the **ratio of mass-flow rates**.
- f) Vertically upwards from this point read off the efficiency for the selected operating conditions.

Notes

- In case of small temperature differences or insignificant moisture contents in the exhaust air, the efficiency remains constant: This is the dry efficiency.
- To roughly determine annual energy savings, the efficiency must be based on annual average temperatures.
- To determine maximum possible power saving, the efficiency must be based on the lowest outside temperature or on the frost limit temperature.

Frost limits

If condensate arises on the exhaust air side and if the heat exchanger surface temperature on the same side drops to below 0°C, freezing is to be expected.

The limitation of the heat exchanger inlet air temperature is dependant upon the heat exchanger model, the specific humidity of the exhaust air flow and the efficiency (ratio of mass flow rates, air flow coefficient).

The frost limit for each installation can be determined from the frost limit diagram.

It shows the outside air temperature at which the formation of frost can occur on the most exposed part of the heat exchanger. Should lower temperatures be anticipated steps must be taken to avoid ice formation.

This is generally done by preheating the outside air to the frost limit temperature or by sector defrosting (page 1). Each heat exchanger type has its own frost limit coefficient which can be read from the data sheets.



Air Fröhlich glass-tube heat exchanger type A, D and E Frost limit determination, efficiency diagram

Frost limit

Kylmän ilmvirran alin lämpötila (Huurtumisraja)
Minimum permissible temperature of cold air at inlet (Frost limit)

Ilmavirtasuhte
Ratio of mass flows
Kylmä virta
Lämmin virta
Cold air flow
Warm air flow

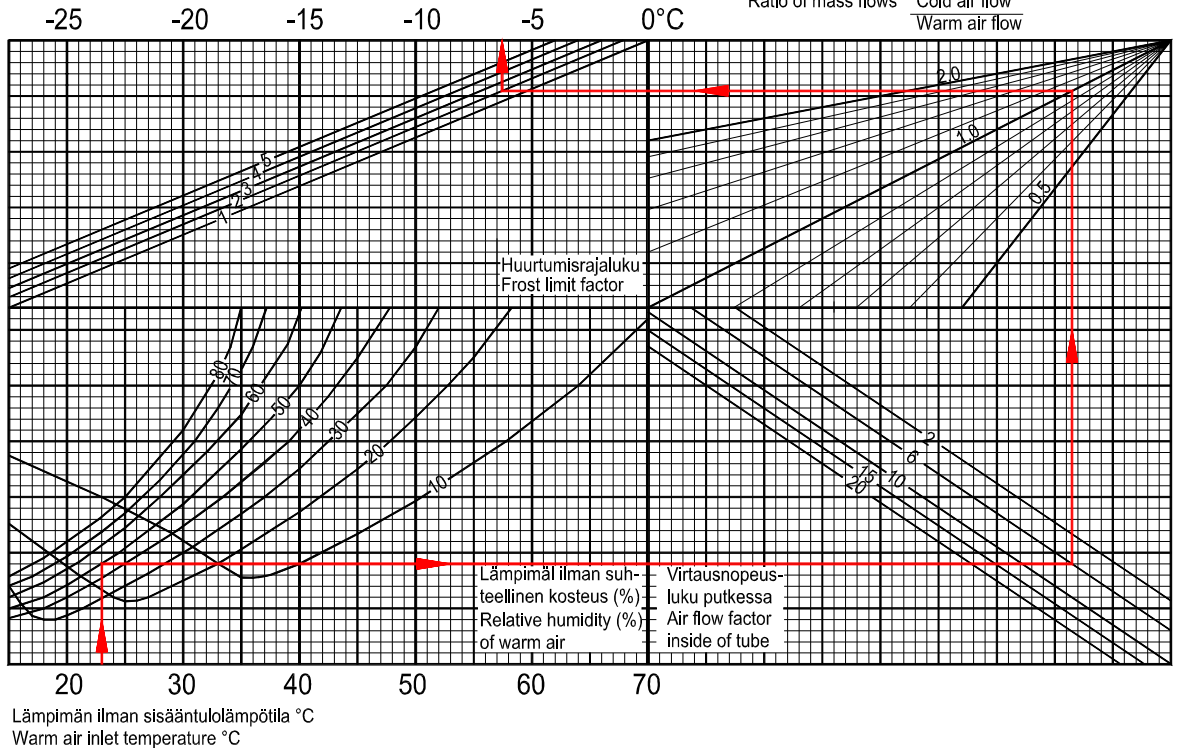

Efficiency

LÄMPÖTILAHYÖTYSUHDE, KYLMÄLLE ILMAVIRRALLE
TEMPERATURE EFFICIENCY, COLD AIR FLOW

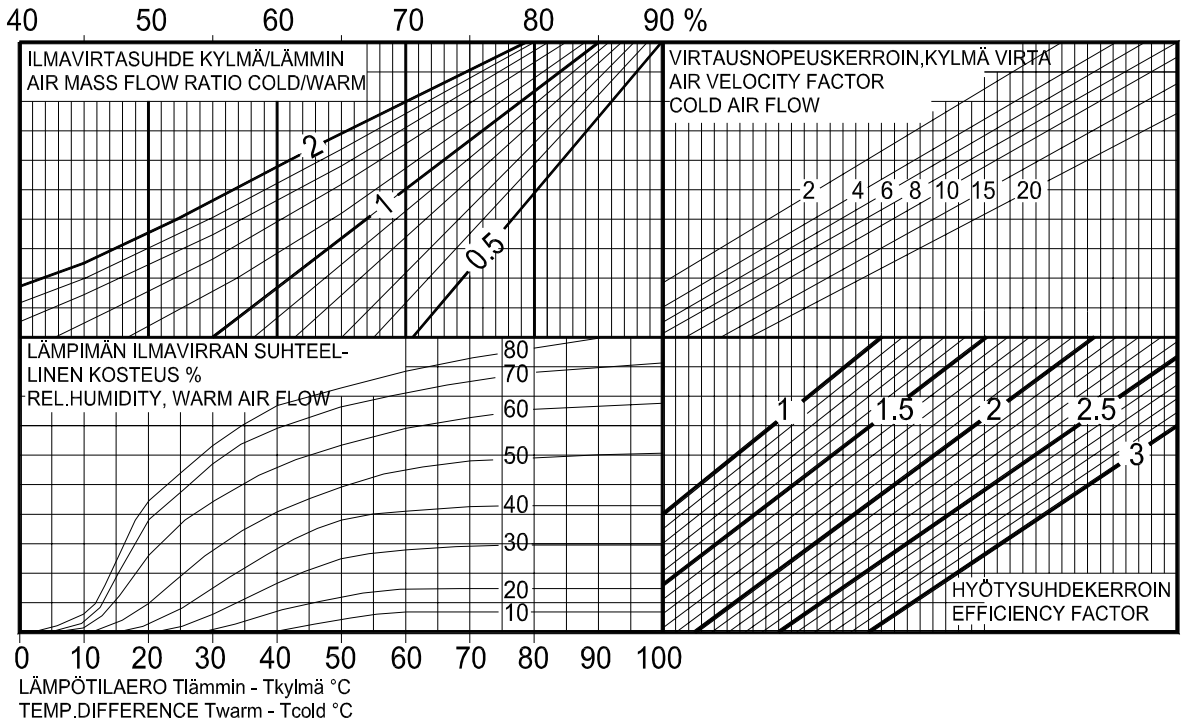

AIR FRÖHLICH ENGINEERING AG

Weidwiesen CH-8587 Oberrach

Switzerland

TANIPLAN OY

00320 Helsinki

Finland