

# **LIFIN dirt strainers**



**Distributor:**

**[www.planmix.fi](http://www.planmix.fi)**

**Planmix Oy**

## LIFIN DIRT STRAINERS

Dirt strainers are intended for mechanical cleaning of the water in District Heating (CHP) and Heat Transfer piping systems to provide safety for heat exchangers, pumps, valves and other equipment and armatures.

Installation of dirt strainers is easy to be made by welding. Installation is possible to be made both in horizontal or vertical way.

The standard net holes of the stainless steel filters are 0,6mm in dimensions DN 25-50 and 1,2mm in dimensions DN 65-200. Other sizes of filter net holes are possible according to client request.

All high quality, CE-marked Lifin Dirt Strainers are pressure tested with water using a pressure of 1,5 x PN.

### MATERIAL SPECIFICATION

1	Elbow	DN 25 – 200	St 35,8	5	Plug sealing	Copper
2	Body		St 35.8	6	Flange	Steel S355
3	Filter		AISI 304	7	Flange sealing	FPM or VMQ
4	Plug		Steel			

### DIMENSIONS

OPERATING TEMPERATURE AREA  
PRESSURE CLASS

DN 25 – 200

0 – 180 C

DN 25 – 50 PN 40

DN 65 – 100 PN 25

DN 125 – 200 PN 16

LIFIN NO	DN	PN	L	∅ds x ls	∅D x s	∅Dd	WEIGHT (kg)	Kv (m3/h)	O-ring inside dimension mm	O-ring thickness mm
100025	25	40	160	36x119	33,7x2,6	106	2,85	22,57	65,0	3,5
100032	32	40	180	45x119	42,4x2,6	106	2,90	32,68	65,0	3,5
100040	40	40	200	50x119	48,3x2,6	106	3,00	37,59	65,0	3,5
100050	50	40	230	63x134	60,3x2,9	106	3,60	99,51	65,0	3,5
100065	65	25	290	78x164	76,1x2,9	124	6,00	133,05	83,0	3,5
100080	80	25	310	93x172	88,9x3,2	138	7,60	160,10	98,0	3,5
100100	100	25	350	120x221	114,3x3,6	180	11,00	458,88	130,0	5,0
100125	125	16	510	148x307	139,7x4,0	235	42,00	740,00		
100150	150	16	565	175x293	168,3x4,5	235	45,00	1100,00		
100200	200	16	750	226x449	219,1x6,3	460	75,00	2000,00		

Strainer nuts -- tightening torques :

100025-100050

Nut M10

tightening torque ~7Nm

100065-100150

Nut M12

tightening torque 10-11Nm

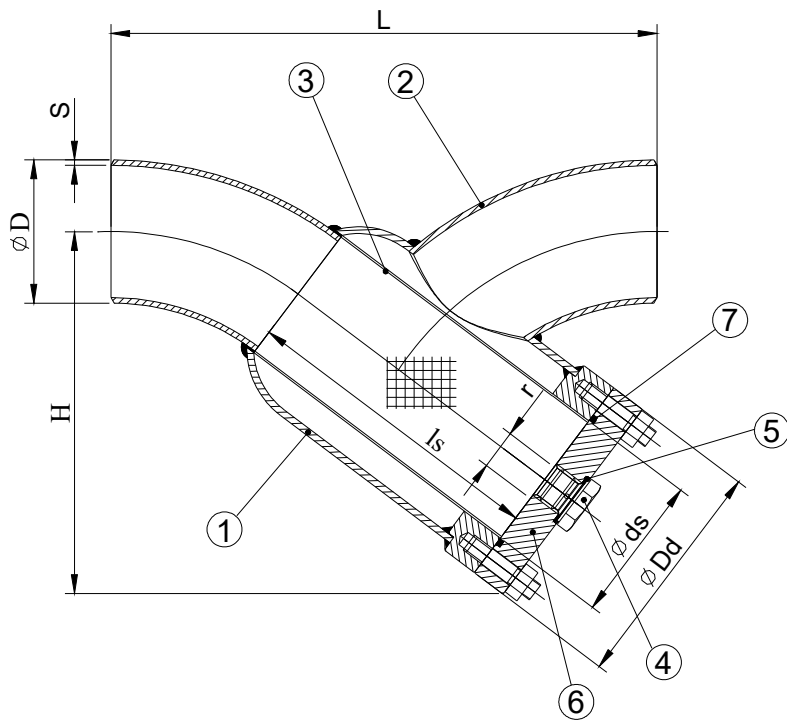
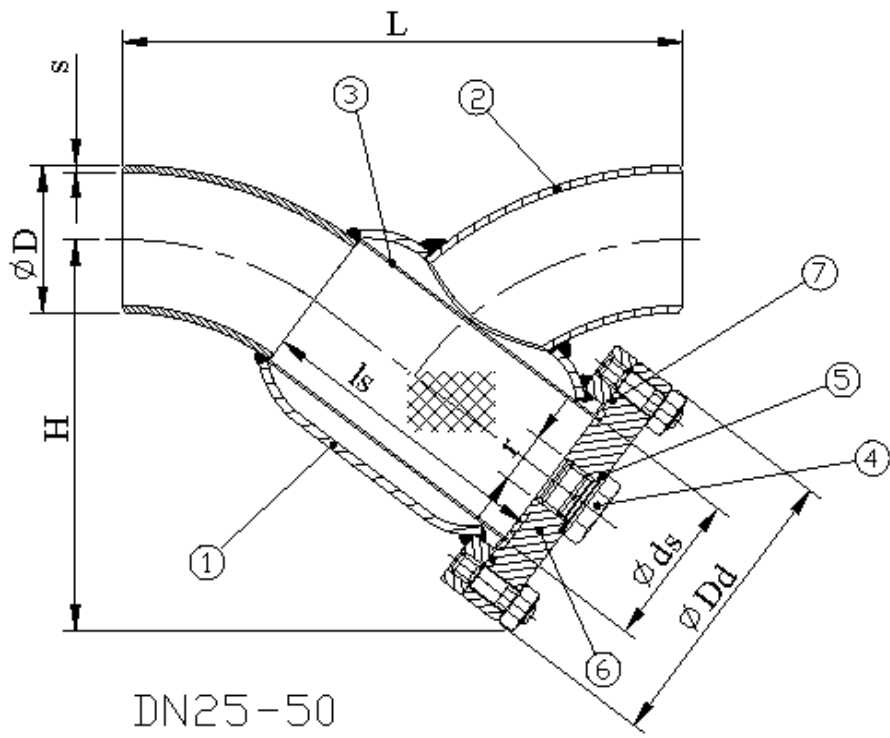

**SALES OFFICE :**

Planmix OY  
Äestäjänkatu 30, 15610 Lahti, FINLAND  
Mob : +358 40 7353426  
Email : [planmix@planmix.fi](mailto:planmix@planmix.fi)  
**[www.planmix.fi](http://www.planmix.fi)**

The logo for Planmix Oy is a red rounded rectangle with the text "Planmix Oy" in white, sans-serif font centered inside.

**MANUFACTURER :**

UAB Lifinata  
Pramones str. 12 A-303  
LT 78150, Siauliai, LITHUANIA  
Email : [lifin@lifin.lt](mailto:lifin@lifin.lt)  
**[www.lifin.lt](http://www.lifin.lt)**

The logo for lifinata is the word "lifinata" in a dark blue, lowercase, sans-serif font. The letter 'i' has a small red triangle above its dot.