

TRU  **WAVE**™

Wave Springs



 **ROTOR CLIP**®

Designed for Quality

Save Space with TRUWAVE Flat Wire Wave Springs.

TruWave flat wire wave springs help to save up to 50% of axial space in your application when compared to conventional coil springs. The result is more compact applications in which unnecessary space and therefore excess material of neighboring components can be reduced to a minimum. The flat wire effectively reduces the solid height of the wave spring so that with the same amount of turns one can visibly reduce the work height without compromising the load or spring deflection. Another advantage is that one can increase the number of turns of the spring design in order to decrease the deflection per turn when the wave spring is compressed. Thus, the spring rate is reduced proportionally to the number of turns and a flat linear characteristic can be generated.

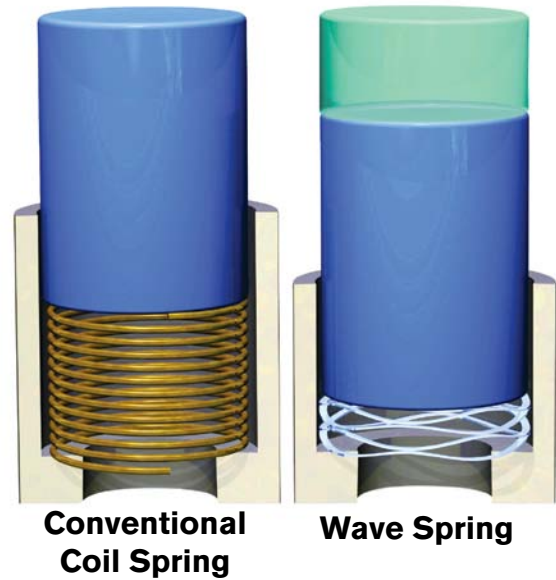

Space Savings

- Reduced Work Height
- Up to 50% of Axial Space Savings compared to conventional coil springs

Flexible Flat Wire Production

- In-house Flat Wire Production for various dimensions
- Special Grades available

Short Delivery Times

- Standard Springs in stock
- No delivery time for special tooling

Despite an extensive standard program in tempered spring steel and stainless steel with different dimensions and spring characteristics, some applications are not served with a standard stock flat wire wave spring. In these instances Rotor Clip offers to produce a special spring according to customer specifications. Rotor Clip's production process does not require special tooling for nonstandard specifications so that the production of a custom spring is equal to that of standard parts.

Contact Rotor Clip's engineers to get help choosing the right flat wire wave spring for your application. Rotor Clip's engineers are able to explain to you, using a special calculation procedure, the suitability of a standard spring for your application or if needed the characteristics of a custom designed spring.

Technical Support

- Computer Aided Spring Calculations
- Installation Solutions

Custom Spring Design

- No Tooling Costs

Spring Characteristics

- Precise specification of the spring load at individual work heights

Quality

- Certified to ISO/TS 16949:2009, ISO 9001:2008

Wave Spring Types

Single Turn Wave Springs



- Gap and Overlap Designs.
- Offered in a number of waves and material thicknesses.
- Designed for wide range of bore and shaft diameters.

Ideal for:

- Narrow radial wall dimensions.
- Light duty applications.
- Moderate Thrust loads.
- Low Clearance applications.
- Ball or Roller Bearing applications.



MST - Single-Turn, Metric.

Ideal for short deflection applications with low to medium forces. Offered in a number of waves and material thicknesses. Designed for a wide range of bore and rod diameter. Specified for several standard bearing diameters.



SST - Single-Turn, Inch.

Ideal for short deflection applications with low to medium forces. Offered in a number of waves and material thicknesses. Designed for a wide range of bore and rod diameter.

Multi Turn Wave Springs



- Compact in Size.
- Occupy 1/3 to 1/2 the axial space.
- Wide variety of loads, deflections, and diameters.

Ideal for:

- Medium & heavy duty applications.
- High thrust load capacity.
- Light & medium bearing series: double row, tapered bearing depending on the ring version.



NST - Single-Turn, Narrow, Inch.

Ideal for short deflection applications where radial space is limited.

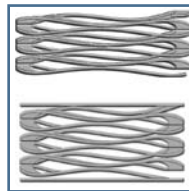

WLS, WSM, WSR - Multi-Turn, Inch.

MWL, MWM, MWR - Multi-Turn, Metric.

Used for low force applications with large deflections: More turns equals less force. Utilizes nearly half the space as helical compression springs while producing the same force.

Material

Each application offers different operating conditions for a flat wire wave spring. Choosing the right material depends on operating temperature, contact with corrosive environments and the required number of load cycles. Rotor Clip's engineers will help you find the right material for your application. An overview of the materials used by Rotor Clip for flat wire wave springs can be found here:

Standard Material Grades

SAE 1070-1090 Carbon Steel (1.1231 - 1.1273)

- This prehardened material is the standard material for wave springs.
- Less expensive option to Stainless Steel.

17-7 Stainless Steel (1.4568 - X7CrNiAl17-7)

- Used for high stress and fatigue applications.
- Can withstand much higher temperatures than SAE 1070-1090 and not lose its spring qualities.
- Higher corrosion resistance than SAE 1070-1090.

Special Material Grades

- AISI 302 Stainless (DIN Material No.: 1.4319)
- AISI 316 Stainless (DIN Material No.: 1.4401)
- A286 (DIN Material No.: 1.4980)
- Inconel X-750 (DIN Material No.: 2.4669)

- Elgiloy (DIN Material No.: 2.4711)
- Hastelloy C276 (DIN Material No.: 2.4819)
- Beryllium-Copper (DIN Material No.: 2.1247)
- Phosphor-Bronze (DIN Material No.: 2.1030)



Ds Dh

TRU WAVE™

Packaging

Rotor Clip supplies Wave Springs in various commercially available packaging options. On demand Rotor Clip packages Wave Springs to your specific requirements.



Wave Spring Selection

Rotor Clip offers a wide range of standard metric and inch size flat wire wave springs with one or multiple turns. Depending on the requirements of each customer's application, we determine if there is a suitable spring available from our standard program or if a custom spring design is necessary. Using the following selection criteria one can easily determine which spring type is best meets the application requirements.

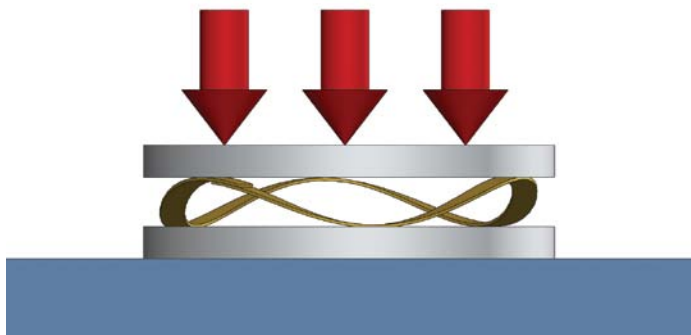

SPRING LOAD AT WORK HEIGHT

By compressing a flat wire wave spring in an axial direction a preload is generated. The axial installation space in an application determines how far the spring is compressed. Here very exact preloads can be specified for this fixed or variable installation space. In variable installation spaces one has to consider if it is a quasi-static application with axial endplay take-up or a dynamic application with a specific number of cycles so that a sufficient lifetime can be achieved.

ONLINE CUSTOM WAVE SPRING CALCULATOR

The custom wave spring calculator allows the input of basic spring/application parameters and returns either a reference drawing to submit for quotation or an error message if the spring is not feasible. Design engineers should know right away if their design or application needs to be adjusted, allowing them to fine tune a nearly-finished product with Technical Sales.

The calculator can be found online: www.rotorclip.com/wsc



PILOTED BY BORE



PILOTED BY SHAFT

DIAMETER & PILOTING

TruWave wave springs are always wound from a continuous flat wire. Designs with multiple turns have no welded or glued connection points. Therefore the spring must be piloted by either a shaft or a bore. This is the only way to safely avoid that individual turns are not skipped. This should be considered when specifying the spring diameter. In addition to an accurate specification of the piloting without radial contact with the shaft or bore wall, a slight grip on the shaft or in the bore can be generated and used as an advantage during the assembly process.

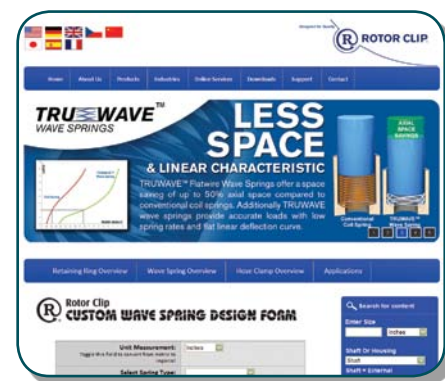

Wave Spring Applications



Spring Cushioned Shoe

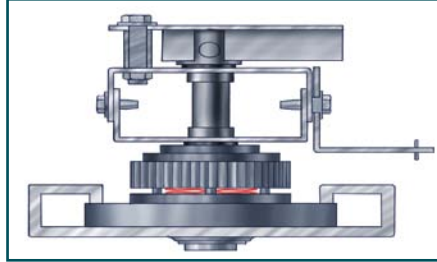

Rolling Door

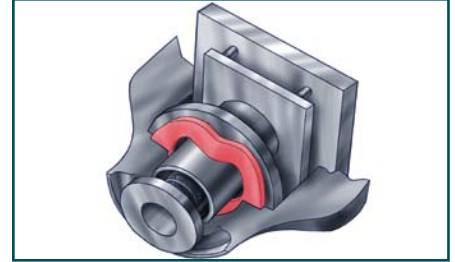

Flash Light Application

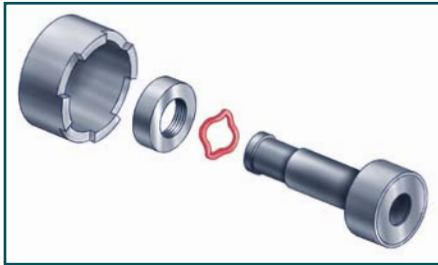

Sprinkler Device

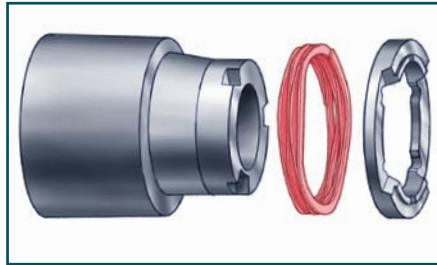

Car Mirror



Night Vision Lens

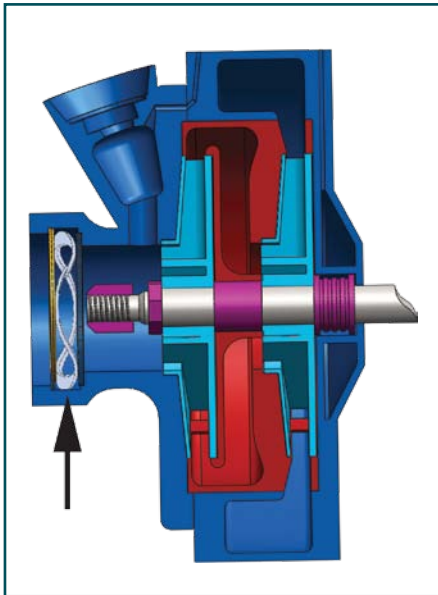

Centrifugal Pump



Airbag Application

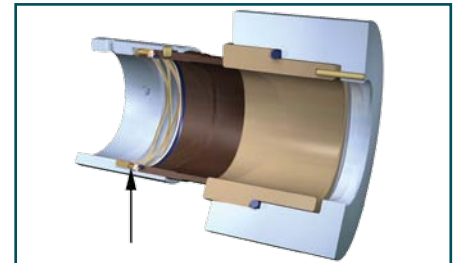

Mechanical Seal

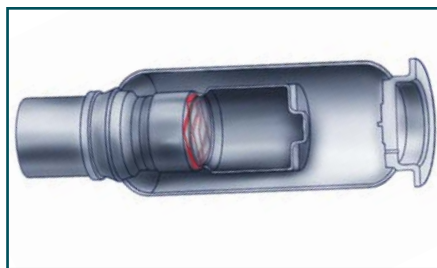

Inflator Application

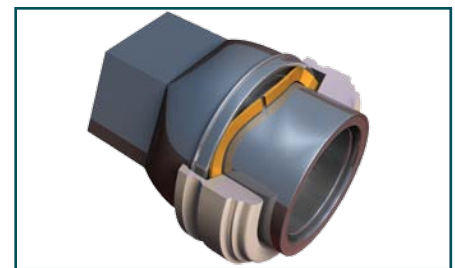

Quick Connect

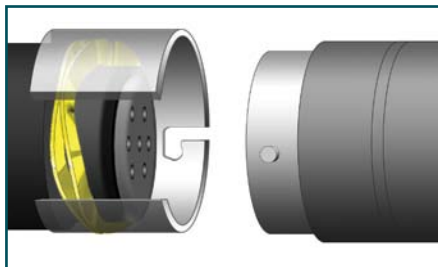

Bayonet Connector



Car Mirror

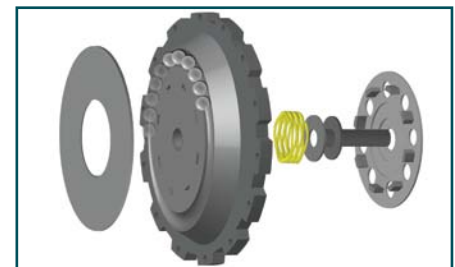

Clutch Application

Quote Form For TRUWAVE Wave Springs

As soon as a standard catalogue item cannot be considered for your application, Rotor Clip can offer custom designed wave springs without expensive tooling costs and with regards to your specification criteria. Please fill out this form and send it to the Rotor Clip engineering department (Fax: +1-732-805-6474, E-Mail: tech@rotorclip.com) which will check a feasible wave spring design with regards to your specifications.

CONTACT INFORMATION		
Name:		Date:
Company:		Department:
Street:		City:
Postal Code / ZIP:		Country:
Phone:	Fax:	Email:

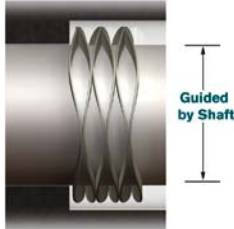
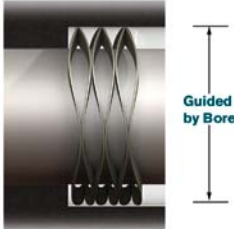



Radial Guide / Pilot	
<p>A multi turn flat wire wave spring has to be guided/piloted radially in order to avoid skipping of the turns. Please indicate a radial guide:</p>	
Bore Diameter: <input type="checkbox"/> [mm] <input type="checkbox"/> [inch]	Shaft Diameter <input type="checkbox"/> [mm] <input type="checkbox"/> [inch]
<input type="checkbox"/> Pilots and Operates in Bore Diameter <input type="checkbox"/> Pilots Over and Clears Shaft Diameter <input type="checkbox"/> Clings in Bore Diameter* <input type="checkbox"/> Clings on Shaft Diameter <small>*for Single Turn Wave Springs only</small>	 

Load Specifications	
Please define the load(s) required at given work height(s). Values in: <input type="checkbox"/> [N] and [mm] or <input type="checkbox"/> [lbs] and [inch]	
Static Application	Dynamic Application/ Endplay Take-up
_____ at _____ Load (Min. / Max.) Work Height	_____ at _____ Load 1 (Min. / Max.) 1. Work Height
	_____ at _____ Load 2 (Min. / Max.) 2. Work Height
Free Height: <input type="checkbox"/> min. <input type="checkbox"/> max.	

Cycle Life	
Please specify the required cycle life:	
<input type="checkbox"/> Static Application	<input type="checkbox"/> 10 ⁵ Cycles <input type="checkbox"/> > 10 ⁶ Cycles
<input type="checkbox"/> < 10 ⁴ Cycles	<input type="checkbox"/> 10 ⁶ Cycles

Operating Conditions	
Please define under which conditions the wave spring is expected to operate:	
Max. Temperature:	°C / °F
The spring will be in contact with:	

Quote Form For TRUWAVE Wave Springs

Type				
				
One turn with gap <input type="checkbox"/>	One turn with overlapping ends <input type="checkbox"/>	Multiple turns with plain ends <input type="checkbox"/>	Multiple turns with parallel ends <input type="checkbox"/>	Multiple nested turns <input type="checkbox"/>

Material (Standard)	
<input type="checkbox"/> Carbon Spring Steel (SAE 1070 – 1090)	<input type="checkbox"/> 17-7PH Condition CH900 Stainless (DIN Material No.: 1.4568)

Special Grades	
<input type="checkbox"/> AISI 302 Stainless (DIN Material No.: 1.4319)	<input type="checkbox"/> Elgiloy (DIN Material No.: 2.4711)
<input type="checkbox"/> AISI 316 Stainless (DIN Material No.: 1.4401)	<input type="checkbox"/> Hastelloy C276 (DIN Material No.: 2.4819)
<input type="checkbox"/> A286 (DIN Material No.: 1.4980)	<input type="checkbox"/> Beryllium-Copper (DIN Material No.: 2.1247)
<input type="checkbox"/> Inconel X-750 (DIN Material No.: 2.4669)	<input type="checkbox"/> Phosphor-Bronze (DIN Material No.: 2.1030)

Finish		
What is the finish requirement of your application:		
<input type="checkbox"/> Oiled (Standard with Carbon Spring Steel)	<input type="checkbox"/> Vibratory Finishing	<input type="checkbox"/> Electropolish
<input type="checkbox"/> Degreased & Ultrasonic-Cleaned (Stainless Steel)	<input type="checkbox"/> Black Oxide	with _____ μm abrasion rate
<input type="checkbox"/> Passivation	<input type="checkbox"/> Deburred	<input type="checkbox"/> Other: _____

Volume	Delivery Time
Prototype Volume:	Prototype:
Series Volume:	Series:

Description of Application / Sketch



Rotor Clip Company, Inc.® - World Headquarters

187 Davidson Avenue, Somerset, NJ 08873 USA
1-800-557-6867 • +1 732-469-7333 • Fax: +1 732-469-7898
www.rotorclip.com

Rotor Clip Czech a.s.

Pražská 403, CZ-411 18 Budyně nad Ohří, Czech Republic
+420 416 863 168 • Fax: +420 416 863 193
e-mail: rotorclipcz@rotorclip.com
www.segnor.cz

Rotor Clip Limited®

Unit 6, Meadowbrook Park, Holbrook, Sheffield, S20 3PJ United Kingdom
+44 (0) 114 247 3399 • Fax: +44 (0) 114 247 4499
e-mail: rc ltd@rotorclip.com
www.rotorclip.co.uk

Rotor Clip GmbH®

Buchwiese 3, D-65510 Idstein/Taunus Germany
+49 (0) 6126 227360 • Fax: +49 (0) 6126 2273619
e-mail: rcgmbh@rotorclip.com
www.rotorclip.de

Rotor Clip China

Room 1510~1511, JH Plaza, 2008 Huqingping Road
Shanghai, 201702 People's Republic of China
e-mail: rcchina@rotorclip.com

